

SE7000 Series Application guide



About Schneider Electric

As a global specialist in energy management with operations in more than 100 countries, Schneider Electric offers integrated solutions across multiple market segments, including a leadership position in non-residential Buildings inclusive of healthcare, education, hotels, retail, life sciences, energy services, green buildings and security.

The SE7000 Series Room Controller offer exemplifies the Company's ability to provide customers with unique solutions that bring out every building's full potential and profitability.

Schneider Electric's SE7000 Series Room Controllers deliver a cost-competitive, building-management solution that puts the customer in control with benefits that include: customisation, optimal occupant comfort, easy installation, scalability, and quick ROI.

Schneider Electric helps customers achieve significant, sustained building performance and energy savings throughout the building life cycle.

Cost-saving, energy-saving applications

From hotels and hospitals to schools, retail, and commercial buildings, Schneider Electric offers wide-ranging room control solutions for your building management needs. Whether retrofitting current systems with a more technologically advanced room controller or going green with a more environmentally friendly option, SE7000 Series is the ideal, cost-competitive solution. The SE7000 Series room controllers can be equipped with an integrated passive infrared motion sensor for demand-based occupancy control that opens up new opportunities in smart energy management.



Open communications

Advance control of your building with truly open, integrated communications. Open protocol options include Zigbee® wireless, BACnet®, and LonWorks® infrastructure.



Lower total install cost

Accelerate your return on investment by saving time and resources from the beginning. Our easy-to-install systems integrate into any new or existing building, with no requirement for costly, specialised labor.



Efficient control

Take full control of your building's HVAC equipment. We'll make it simple with intuitive, application-based products specifically designed for your needs.



Occupancy sensing

Equip your room controller with an integrated passive infrared motion sensor for demand-based occupancy control that raises your energy efficiency to a whole new level.



Energy savings

Save energy. Save money. With SE7000 Series room controllers you'll reduce energy costs without sacrificing comfort one bit.



Temperature and humidity sensing

Deliver efficient, measurable control. If you can measure it, you can control it — providing more precise occupant comfort and productivity.

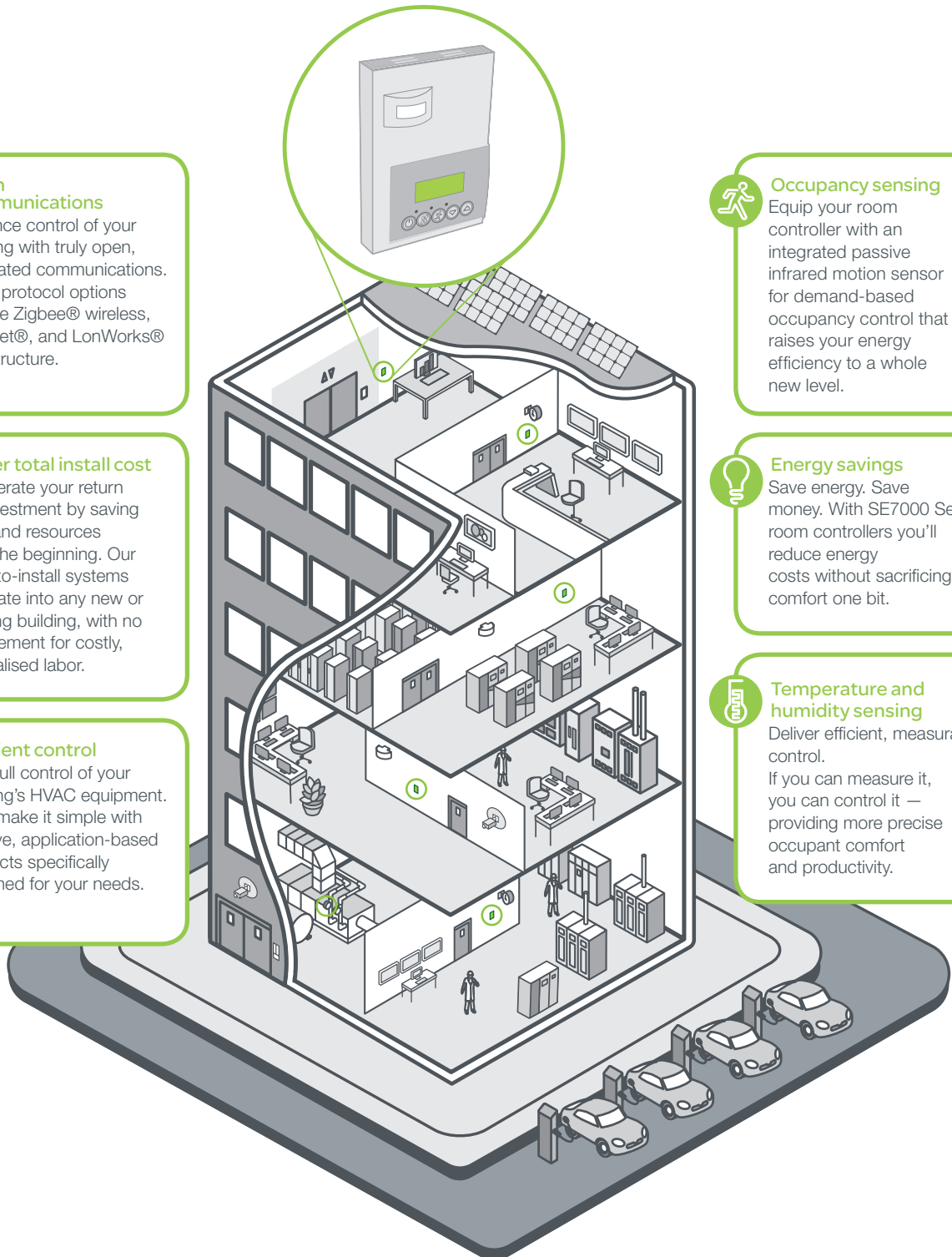

Schneider Electric SE7000 Series room controllers bridge the gap between stand-alone sensors and intelligent building management systems, delivering simplified automation and communications to a broad range of mid-market opportunities.



Healthcare



Retail



Education



Hotels

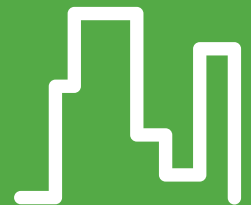

Commercial

Table of Contents

Product Part Number Guides **A-1**

SE7200 Zone Controllers **B-1**

SE7300 Fan Coil Controllers **C-1**

SE7600 Roof Top and
Heat Pump Controllers **D-1**

Appendices **E-1**





Introducing simplified building management

Schneider Electric introduces the new SE7000 Series room controllers, delivering advanced climate control at an affordable price for mid-market applications. The SE7000 Series offers a variety of application-specific products to increase the comfort of building occupants while reducing energy costs and consumption and accelerating return on investment. The digital controllers give users easy-to-install, thermostat-like functionality that can sense occupancy and adjust set-point or fan speed control. From roof top to fan coil, to terminal unit and heat pump applications, you'll be in full control.

Products

VCM7000 Network Ready Communication Adapters	A-3
SE7200 Series Zoning Controller Part Numbering	A-4
SE7300 Series Fan Coil Unit Controller Part Numbering	A-5
SE7600 Series Roof Top and Heat Pump Controller Part Numbering	A-6



Digital stand-alone and communicating room controllers

Schneider Electric offers three room controller models to meet your specific application-based needs. All models feature an intuitive user interface with a backlit LCD display and configurable system and fan functions for optimal control in any application. For zoning applications, the SE7200 Series includes local hydronic reheat valve control and pressure dependent VAV (with or without local reheat). The SE7300 Series is specifically designed for fan coil control. Models are available with on/off, three-point floating, or analogue outputs. The SE7600 Series can be installed in any building using a standard roof top or heat pump unit with a requirement for advanced control.



SE7200 Series	SE7300 Series	SE7600 Series
Zoning, heating/cooling	Fan coil, three-speed fan	Roof top or heat pump
<ul style="list-style-type: none"> • Reheat control • Induction units • Chilled beam • Under floor heating • Perimeter radiant heat • Pressure dependent VAV 	<ul style="list-style-type: none"> • Two pipe • Four pipe 	<ul style="list-style-type: none"> • Economiser option • Humidification/dehumidification heat pumps • Roof top, 3 heat/2 cool • Water source with dehumidification, 1 heat/2 cool

- Flexible addition of network communications
- Easily integrate into building automation system

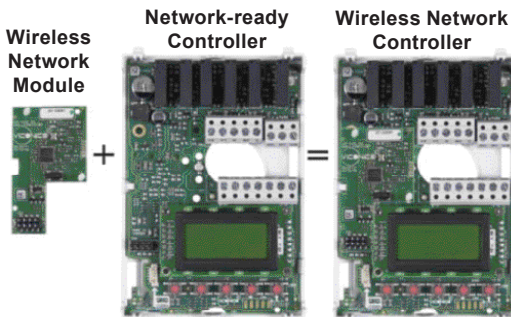
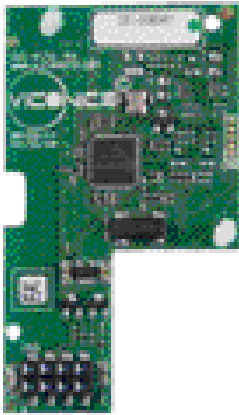

Description

All current "Network Ready" Schneider Electric SE7000 Series controllers are capable of being retrofitted in the field with accessory communication adapters that enable the controllers to be integrated into virtually all leading building automation systems.

This approach provides the flexibility to add network communication strategies as budgets allow, or as building-management needs change.

The manufacturing date is marked inside the controller on a small label which also contains the part number. The format of the date code is year / week. If in doubt, please contact the factory for assistance. Always verify the manufacturing date code of all thermostats before ordering any communication modules.

Example: Date code 1115 signifies that it is manufactured in 2011 on the 15th week of the year.

If required, Network-ready (Stand-Alone) Terminal Equipment Controllers can be field retrofitted with the communication adapters listed below.



Model	Description
VCM7000V5045W	Wireless Communication Card for all SE7000 BACnet®
VCM7300V5045B	BACnet® Communication Card for all SE7200 & SE7300 Series
VCM7300T5045B	BACnet® Communication Card for all SE7300 Series
VCM7600V5045B	BACnet® Communication Card for all SE7600 Series
VCM7607V5045B	BACnet® Communication Card for all SE76x7 with RH Echelon®
VCM7300V5045E	Echelon® Communication Card for all SE7200 & SE7300 Series
VCM7300T5045E	Echelon Communication card for all SER7300
VCM7600V5045E	Echelon® Communication Card for all SE7600 Series
VCM7607V5045E	Echelon® Communication Card for all SE76x7 with RH ZigBee®
VCM7200V5045P	Wireless ZigBee® Pro Communication card for all SE7200
VCM7300V5045P	Wireless ZigBee® Pro Communication card for all SE7300 without RH
VCM7300R5045P	Wireless ZigBee® Pro Communication card for all SE7300 with RH
VCM7600V5045P	Wireless ZigBee® Pro Communication card for all SE7600 without RH
VCM7607V5045P	Wireless ZigBee® Pro Communication card for all SE7600 with RH

Specifications

Operating conditions	0 °C to 50 °C (32 °F to 122 °F) 0% to 95% R.H. non-condensing
Storage conditions	-30 °C to 50 °C (-22 °F to 122 °F) 0% to 95% R.H. non-condensing
Shipping weight approx..	0.75 lb (0.34 kg)
Agency Approvals all models	UL: UL 873 (US) and CSA C22.2 No. 24 (Canada), File E27734 with CCN XAPX (US) and XAPX7 (Canada) Industry Canada: ICES-003 (Canada)
Agency Approvals all models	FCC: Compliant to CFR 47, Part 15, Subpart B (US) CE: EMC Directive 89/336/EEC (Europe Union) C-Tick: AS/NZS CISPR 22 Compliant (Australia / New Zealand) Supplier Code Number N10696
Agency Approvals wireless models	FCC: Compliant to: Part 15, Subpart C

SE7200 Series Zoning Controller Part Numbering



When ordering controllers, structure part numbers for the options desired as indicated below.

SE7200 Series ordering

SE7200 [] [] [] **45** [] []

Example:

SE7200F5045B

- Zone Control
- Analogue 0 - 10 VDC outputs
- PIR ready
- Schneider Electric branded
- BACnet communications

Control output type:

- C = Floating or on/off digital control outputs
- F = Analogue 0 - 10 VDC control outputs

PIR options:

- 50 = PIR ready but PIR cover not included
- 55 = Factory assembled with PIR cover

Communication options:

- B = BACnet® MS/TP
- E = Echelon®
- P = ZigBee Pro wireless
- W = Zigbee® wireless
- = Network ready

Accessories options:

- VWA = Wireless door and window switch compatible
- Note: -VWA compatible only with -W (ZigBee) controller models

* Some part number configurations may not be available. Please refer to the table below for available versions.

SE7200 | Zone controllers

Part Number	Description	Output	PIR Cover	Communication
SE7200C5045	Stand-alone zone controller	Floating or on/off	No	Stand-alone (network ready)
SE7200C5045B	BACnet zone controller	Floating or on/off	No	BACnet
SE7200C5045E	LON zone controller	Floating or on/off	No	LonWorks
SE7200C5045P	ZigBee Pro wireless zone controller	Floating or on/off	No	ZigBee Pro
SE7200C5045W	Wireless zone controller	Floating or on/off	No	Wireless
SE7200C5045W-VWA	Wireless zone controller	Floating or on/off	No	Wireless
SE7200C5545	Stand-alone zone controller	Floating or on/off	Yes	Stand-alone (network ready)
SE7200C5545B	BACnet zone controller	Floating or on/off	Yes	BACnet
SE7200C5545E	LON zone controller	Floating or on/off	Yes	LonWorks
SE7200C5545P	ZigBee Pro wireless zone controller	Floating or on/off	Yes	ZigBee Pro
SE7200C5545W	Wireless zone controller	Floating or on/off	Yes	Wireless
SE7200C5545W-VWA	Wireless zone controller	Floating or on/off	Yes	Wireless
SE7200F5045	Stand-alone zone controller	0 - 10 V	No	Stand-alone (network ready)
SE7200F5045B	BACnet zone controller	0 - 10 V	No	BACnet
SE7200F5045E	LON zone controller	0 - 10 V	No	LonWorks
SE7200F5045P	ZigBee Pro wireless zone controller	Floating or on/off	No	ZigBee Pro
SE7200F5045W	Wireless zone controller	0 - 10 V	No	Wireless
SE7200F5045W-VWA	Wireless zone controller	0 - 10 V	No	Wireless
SE7200F5545	Stand-alone zone controller	0 - 10 V	Yes	Stand-alone (network ready)
SE7200F5545B	BACnet zone controller	0 - 10 V	Yes	BACnet
SE7200F5545E	LON zone controller	0 - 10 V	Yes	LonWorks
SE7200F5545P	ZigBee Pro wireless zone controller	Floating or on/off	Yes	ZigBee Pro
SE7200F5545W	Wireless zone controller	0 - 10 V	Yes	Wireless
SE7200F5545W-VWA	Wireless zone controller	Floating or on/off	Yes	Wireless

SE7300 Series Fan Coil Unit Controller Part Numbering



When ordering controllers, structure part numbers for the options desired as indicated below.

SE7300 Series ordering

SE73 **45**

Humidity sensor and control:
 -0 = No humidity sensor
 -5 = Internal humidity sensor

PIR options:
 -50 = PIR ready but PIR cover not included
 -55 = Factory assembled with PIR cover

Compatibility:
 -C = Floating or on/off digital control outputs
 -F = Analogue 0 - 10 VDC control outputs

Control key function:
 -0 = Override, for commercial applications
 -5 = °C/°F, for hotels/lodging applications

Accessories options:
 -ECM = For fan coil applications that have ECM motors
 -VWA = Wireless door and window switch compatible
 Note: -VWA compatible only with -W (ZigBee) controller models

Communication options:
 -B = BACnet® MS/TP
 -E = Echelon®
 -P = ZigBee Pro wireless
 -W = Zigbee® wireless
 - = Network ready

Example:
SE7355C5545B

- Fan coil
- Internal humidity sensor
- Hospitality
- Floating control
- Factory installed PIR cover
- Schneider Electric branded
- LON communications

* Some part number configurations may not be available. Please refer to the table below for available versions.

SE7300 Series Fan Coil Unit Controller Part Numbering

SE7300 | Fan coil room controllers

Part Number	Description	Humidity	Output	PIR Cover	Communication
SE7300C5045	Stand-alone fan coil controller	No	Floating or on/off	No	Stand-alone (network ready)
SE7300C5045B	BACnet fan coil controller	No	Floating or on/off	No	BACnet
SE7300C5045E	LON fan coil controller	No	Floating or on/off	No	LonWorks
SE7300C5045P	ZigBee Pro wireless zone controller	No	Floating or on/off	No	ZigBee Pro
SE7300C5045W	Wireless fan coil controller	No	Floating or on/off	No	Wireless
SE7300C5045W-VWA	Wireless fan coil controller	No	Floating or on/off	No	Wireless
SE7300C5545	Stand-alone fan coil controller	No	Floating or on/off	Yes	Stand-alone (network ready)
SE7300C5545B	BACnet fan coil controller	No	Floating or on/off	Yes	BACnet
SE7300C5545E	LON fan coil controller	No	Floating or on/off	Yes	LonWorks
SE7300C5545P	ZigBee Pro wireless zone controller	No	Floating or on/off	Yes	ZigBee Pro
SE7300C5545W	Wireless fan coil controller	No	Floating or on/off	Yes	Wireless
SE7300C5545W-VWA	Wireless fan coil controller	No	Floating or on/off	Yes	Wireless
SE7300F5045	Stand-alone fan coil controller	No	0 - 10 V	No	Stand-alone (network ready)
SE7300F5045B	BACnet fan coil controller	No	0 - 10 V	No	BACnet
SE7300F5045E	LON fan coil controller	No	0 - 10 V	No	LonWorks
SE7300F5045P	ZigBee Pro wireless zone controller	No	0 - 10 V	No	ZigBee Pro
SE7300F5045W	Wireless fan coil controller	No	0 - 10 V	No	Wireless
SE7300F5045W-VWA	Wireless fan coil controller	No	0 - 10 V	No	Wireless
SE7300F5545	Stand-alone fan coil controller	No	0 - 10 V	Yes	Stand-alone (network ready)
SE7300F5545B	BACnet fan coil controller	No	0 - 10 V	Yes	BACnet
SE7300F5545E	LON fan coil controller	No	0 - 10 V	Yes	LonWorks
SE7300F5545P	ZigBee Pro wireless zone controller	No	0 - 10 V	Yes	ZigBee Pro
SE7300F5545W	Wireless fan coil controller	No	0 - 10 V	Yes	Wireless
SE7300F5545W-VWA	Wireless fan coil controller	No	0 - 10 V	Yes	Wireless
SE7350C5045	Stand-alone fan coil controller	Yes	Floating or on/off	No	Stand-alone (network ready)
SE7350C5045B	BACnet fan coil controller	Yes	Floating or on/off	No	BACnet
SE7350C5045E	LON fan coil controller	Yes	Floating or on/off	No	LonWorks
SE7350C5045P	ZigBee Pro wireless zone controller	Yes	Floating or on/off	No	ZigBee Pro
SE7350C5045W	Wireless fan coil controller	Yes	Floating or on/off	No	Wireless
SE7350C5045W-VWA	Wireless fan coil controller	Yes	Floating or on/off	No	Wireless
SE7350C5545	Stand-alone fan coil controller	Yes	Floating or on/off	Yes	Stand-alone (network ready)
SE7350C5545B	BACnet fan coil controller	Yes	Floating or on/off	Yes	BACnet
SE7350C5545E	LON fan coil controller	Yes	Floating or on/off	Yes	LonWorks
SE7350C5545P	ZigBee Pro wireless zone controller	Yes	Floating or on/off	Yes	ZigBee Pro
SE7350C5545W	Wireless fan coil controller	Yes	Floating or on/off	Yes	Wireless
SE7350C5545W-VWA	Wireless fan y controller	Yes	Floating or on/off	Yes	Wireless
SE7350F5045	Stand-alone fan coil controller	Yes	0 - 10 V	No	Stand-alone (network ready)
SE7350F5045B	BACnet fan coil controller	Yes	0 - 10 V	No	BACnet
SE7350F5045E	LON fan coil controller	Yes	0 - 10 V	No	LonWorks
SE7350F5045P	ZigBee Pro wireless zone controller	Yes	0 - 10 V	Yes	ZigBee Pro
SE7350F5045W	Wireless fan coil controller	Yes	0 - 10 V	No	Wireless
SE7350F5045W-VWA	Wireless fan coil controller	Yes	0 - 10 V	No	Wireless
SE7350F5545	Stand-alone fan coil controller	Yes	0 - 10 V	Yes	Stand-alone (network ready)
SE7350F5545B	BACnet fan coil controller	Yes	0 - 10 V	Yes	BACnet
SE7350F5545E	LON fan coil controller	Yes	0 - 10 V	Yes	LonWorks
SE7350F5545P	ZigBee Pro wireless zone controller	Yes	0 - 10 V	Yes	ZigBee Pro
SE7350F5545W	Wireless fan coil controller	Yes	0 - 10 V	Yes	Wireless
SE7350F5545W-VWA	Wireless fan coil controller	Yes	0 - 10 V	Yes	Wireless

SE7300 Series Fan Coil Unit Controller Part Numbering

SE7305 | Fan coil room controllers

Part Number	Description	Humidity	Output	PIR Cover	Communication
SE7305C5045	Stand-alone fan coil controller	No	Floating or on/off	No	Stand-alone (network ready)
SE7305C5045B	BACnet fan coil controller	No	Floating or on/off	No	BACnet
SE7305C5045E	LON fan coil controller	No	Floating or on/off	No	LonWorks
SE7305C5045P	ZigBee Pro wireless zone controller	No	Floating or on/off	No	ZigBee Pro
SE7305C5045W	Wireless fan coil controller	No	Floating or on/off	No	Wireless
SE7305C5045W-VWA	Wireless fan coil controller	No	Floating or on/off	No	Wireless
SE7305C5545	Stand-alone fan coil controller	No	Floating or on/off	Yes	Stand-alone (network ready)
SE7305C5545B	BACnet fan coil controller	No	Floating or on/off	Yes	BACnet
SE7305C5545E	LON fan coil controller	No	Floating or on/off	Yes	LonWorks
SE7305C5545P	ZigBee Pro wireless zone controller	No	Floating or on/off	Yes	ZigBee Pro
SE7305C5545W	Wireless fan coil controller	No	Floating or on/off	Yes	Wireless
SE7305C5545W-VWA	Wireless fan coil controller	No	Floating or on/off	Yes	Wireless
SE7305F5045	Stand-alone fan coil controller	No	0 - 10 V	No	Stand-alone (network ready)
SE7305F5045B	BACnet fan coil controller	No	0 - 10 V	No	BACnet
SE7305F5045E	LON fan coil controller	No	0 - 10 V	No	LonWorks
SE7305F5045P	ZigBee Pro wireless zone controller	No	0 - 10 V	No	ZigBee Pro
SE7305F5045W	Wireless fan coil controller	No	0 - 10 V	No	Wireless
SE7305F5045W-VWA	Wireless fan coil controller	No	0 - 10 V	No	Wireless
SE7305F5545	Stand-alone fan coil controller	No	0 - 10 V	Yes	Stand-alone (network ready)
SE7305F5545B	BACnet fan coil controller	No	0 - 10 V	Yes	BACnet
SE7305F5545E	LON fan coil controller	No	0 - 10 V	Yes	LonWorks
SE7305F5545P	ZigBee Pro wireless zone controller	No	0 - 10 V	Yes	ZigBee Pro
SE7305F5545W	Wireless fan coil controller	No	0 - 10 V	Yes	Wireless
SE7305F5545W-VWA	Wireless fan coil controllercontroller	No	0 - 10 V	Yes	Wireless
SE7355C5045	Stand-alone fan coil controller	Yes	Floating or on/off	No	Stand-alone (network ready)
SE7355C5045B	BACnet fan coil controller	Yes	Floating or on/off	No	BACnet
SE7355C5045E	LON fan coil controller	Yes	Floating or on/off	No	LonWorks
SE7355C5045P	ZigBee Pro wireless zone controller	Yes	Floating or on/off	No	ZigBee Pro
SE7355C5045W	Wireless fan coil controller	Yes	Floating or on/off	No	Wireless
SE7355C5045W-VWA	Wireless fan coil controller	Yes	Floating or on/off	No	Wireless
SE7355C5545	Stand-alone fan coil controller	Yes	Floating or on/off	Yes	Stand-alone (network ready)
SE7355C5545B	BACnet fan coil controller	Yes	Floating or on/off	Yes	BACnet
SE7355C5545E	LON fan coil controller	Yes	Floating or on/off	Yes	LonWorks
SE7355C5545P	ZigBee Pro wireless zone controller	Yes	Floating or on/off	Yes	ZigBee Pro
SE7355C5545W	Wireless fan coil controller	Yes	Floating or on/off	Yes	Wireless
SE7355C5545W-VWA	Wireless fan coil controller	Yes	Floating or on/off	Yes	Wireless
SE7355F5045	Stand-alone fan coil controller	Yes	0 - 10 V	No	Stand-alone (network ready)
SE7355F5045B	BACnet fan coil controller	Yes	0 - 10 V	No	BACnet
SE7355F5045E	LON fan coil controller	Yes	0 - 10 V	No	LonWorks
SE7355F5045P	ZigBee Pro wireless zone controller	Yes	0 - 10 V	No	ZigBee Pro
SE7355F5045W	Wireless fan coil controller	Yes	0 - 10 V	No	Wireless
SE7355F5545W-VWA	Wireless fan coil controller	Yes	0 - 10 V	No	Wireless
SE7355F5545	Stand-alone fan coil controller	Yes	0 - 10 V	Yes	Stand-alone (network ready)
SE7355F5545B	BACnet fan coil controller	Yes	0 - 10 V	Yes	BACnet
SE7355F5545E	LON fan coil controller	Yes	0 - 10 V	Yes	LonWorks
SE7355F5545P	ZigBee Pro wireless zone controller	Yes	0 - 10 V	Yes	ZigBee Pro
SE7355F5545W	Wireless fan coil controller	Yes	0 - 10 V	Yes	Wireless
SE7355F5545W-VWA	Wireless fan coil controller	Yes	0 - 10 V	Yes	Wireless

SE7600 Series Roof Top and Heat Pump Controller Part Numbering



When ordering controllers, structure part numbers for the options desired as indicated below.

SE7600 Series ordering

SE76 45

Programmability:
 -0 = No local scheduling / non programmable
 -5 = Local scheduling / programmable

Economiser / Humidity control:
 -0 = No local scheduling / Non programmable
 -2 = Local scheduling / Programmable
 -5 = With economiser no local scheduling / Non programmable
 -6 = With economiser local scheduling / Programmable
 -7 = With Humidification / Dehumidification control

Example:
SE7652H5045E

- Roof Top Controller
- No local scheduling or programming
- 2H / 2C Application
- PIR Ready
- Echelon® wireless communication

PIR options:
 -50 = PIR ready but PIR cover not included
 -55 = Factory assembled with PIR cover

Compatibility:
 -A = 1H / 1C roof top unit applications
 -B = 2H / 2C roof top unit applications
 -E = 2H / 2C IAQ applications
 -F = 1H / 2C modulating heat applications
 -H = 3H / 2C heat pump applications
 -W = 2H / 2C water source heat pump applications

Communication options:
 -B = BACnet® MS/TP
 -E = Echelon®
 -P = ZigBee Pro wireless
 -W = Zigbee® wireless
 - = Network ready

* Some part number configurations may not be available. Please refer to the tables that follow for available versions.

SE7600 Series Roof Top and Heat Pump Controller Part Numbering

SE7600A and SE7600B | Roof top controllers

Part Number	Description	Scheduling	Economiser	Heat/Cool Stages	Humidity	PIR Cover	Communication
SE7600A5045	Stand-alone roof top controller	No	No	1H/1C	No	No	Stand-alone (network ready)
SE7600A5045B	BACnet roof top controller	No	No	1H/1C	No	No	BACnet
SE7600A5045E	LON roof top controller	No	No	1H/1C	No	No	LonWorks
SE7600A5045P	ZigBee Pro wireless roof top controller	No	No	1H/1C	No	No	ZigBee Pro
SE7600A5045W	Wireless roof top controller	No	No	1H/1C	No	No	Wireless
SE7600A5545	Stand-alone roof top controller	No	No	1H/1C	No	Yes	Stand-alone (network ready)
SE7600A5545B	BACnet roof top controller	No	No	1H/1C	No	Yes	BACnet
SE7600A5545E	LON roof top controller	No	No	1H/1C	No	Yes	LonWorks
SE7600A5545P	ZigBee Pro wireless roof top controller	No	No	1H/1C	No	Yes	ZigBee Pro
SE7600A5545W	Wireless roof top controller	No	No	1H/1C	No	Yes	Wireless
SE7600B5045	Stand-alone roof top controller	No	No	2H/2C	No	No	Stand-alone (network ready)
SE7600B5045B	BACnet roof top controller	No	No	2H/2C	No	No	BACnet
SE7600B5045E	LON roof top controller	No	No	2H/2C	No	No	LonWorks
SE7600A5045P	ZigBee Pro wireless roof top controller	No	No	2H/2C	No	No	ZigBee Pro
SE7600B5045W	Wireless roof top controller	No	No	2H/2C	No	No	Wireless
SE7600B5545	Stand-alone roof top controller	No	No	2H/2C	No	Yes	Stand-alone (network ready)
SE7600B5545B	BACnet roof top controller	No	No	2H/2C	No	Yes	BACnet
SE7600B5545E	LON roof top controller	No	No	2H/2C	No	Yes	LonWorks
SE7600B5545P	ZigBee Pro wireless roof top controller	No	No	2H/2C	No	Yes	ZigBee Pro
SE7600B5545W	Wireless roof top controller	No	No	2H/2C	No	Yes	Wireless
SE7605B5045	Stand-alone roof top controller	No	Yes	2H/2C	No	No	Stand-alone (network ready)
SE7605B5045B	BACnet roof top controller	No	Yes	2H/2C	No	No	BACnet
SE7605B5045E	LON roof top controller	No	Yes	2H/2C	No	No	LonWorks
SE7605B5045P	ZigBee Pro wireless roof top controller	No	Yes	2H/2C	No	No	ZigBee Pro
SE7605B5045W	Wireless roof top controller	No	Yes	2H/2C	No	No	Wireless
SE7605B5545	Stand-alone roof top controller	No	Yes	2H/2C	No	Yes	Stand-alone (network ready)
SE7605B5545B	BACnet roof top controller	No	Yes	2H/2C	No	Yes	BACnet
SE7605B5545E	LON roof top controller	No	Yes	2H/2C	No	Yes	LonWorks
SE7605B5545P	ZigBee Pro wireless roof top controller	No	Yes	2H/2C	No	Yes	ZigBee Pro
SE7605B5545W	Wireless roof top controller	No	Yes	2H/2C	No	Yes	Wireless
SE7607B5045	Stand-alone roof top controller	No	No	2H/2C	Yes	No	Stand-alone (network ready)
SE7607B5045B	BACnet roof top controller	No	No	2H/2C	Yes	No	BACnet
SE7607B5045E	LON roof top controller	No	No	2H/2C	Yes	No	LonWorks
SE7607B5045P	ZigBee Pro wireless roof top controller	No	No	2H/2C	Yes	No	ZigBee Pro
SE7607B5045W	Wireless roof top controller	No	No	2H/2C	Yes	No	Wireless
SE7607B5545	Stand-alone roof top controller	No	No	2H/2C	Yes	Yes	Stand-alone (network ready)
SE7607B5545B	BACnet roof top controller	No	No	2H/2C	Yes	Yes	BACnet
SE7607B5545E	LON roof top controller	No	No	2H/2C	Yes	Yes	LonWorks
SE7607B5545P	ZigBee Pro wireless roof top controller	No	No	2H/2C	Yes	Yes	ZigBee Pro
SE7607B5545W	Wireless roof top controller	No	No	2H/2C	Yes	Yes	Wireless
SE7652A5045	Stand-alone roof top controller	Yes	No	1H/1C	No	No	Stand-alone (network ready)
SE7652A5045B	BACnet roof top controller	Yes	No	1H/1C	No	No	BACnet
SE7652A5045E	LON roof top controller	Yes	No	1H/1C	No	No	LonWorks
SE7652A5045P	ZigBee Pro wireless roof top controller	Yes	No	1H/1C	No	No	ZigBee Pro
SE7652A5045W	Wireless roof top controller	Yes	No	1H/1C	No	No	Wireless
SE7652A5545	Stand-alone roof top controller	Yes	No	1H/1C	No	Yes	Stand-alone (network ready)
SE7652A5545B	BACnet roof top controller	Yes	No	1H/1C	No	Yes	BACnet
SE7652A5545E	LON roof top controller	Yes	No	1H/1C	No	Yes	LonWorks
SE7652A5545P	ZigBee Pro wireless roof top controller	Yes	No	1H/1C	No	Yes	ZigBee Pro
SE7652A5545W	Wireless roof top controller	Yes	No	1H/1C	No	Yes	Wireless
SE7652B5045	Stand-alone roof top controller	Yes	No	2H/2C	No	No	Stand-alone (network ready)

SE7600 Series Roof Top and Heat Pump Controller Part Numbering

SE7600A and SE7600B | Roof top controllers

Part Number	Description	Scheduling	Economiser	Heat/Cool Stages	Humidity	PIR Cover	Communication
SE7652B5045B	BACnet roof top controller	Yes	No	2H/2C	No	No	BACnet
SE7652B5045E	LON roof top controller	Yes	No	2H/2C	No	No	LonWorks
SE7652B5045P	ZigBee Pro wireless roof top controller	Yes	No	2H/2C	No	No	ZigBee Pro
SE7652B5045W	Wireless roof top controller	Yes	No	2H/2C	No	No	Wireless
SE7652B5545	Stand-alone roof top controller	Yes	No	2H/2C	No	Yes	Stand-alone (network ready)
SE7652B5545B	BACnet roof top controller	Yes	No	2H/2C	No	Yes	BACnet
SE7652B5545E	LON roof top controller	Yes	No	2H/2C	No	Yes	LonWorks
SE7652B5545P	ZigBee Pro wireless roof top controller	Yes	No	2H/2C	No	Yes	ZigBee Pro
SE7652B5545W	Wireless roof top controller	Yes	No	2H/2C	No	Yes	Wireless
SE7656B5045	Stand-alone roof top controller	Yes	Yes	2H/2C	No	No	Stand-alone (network ready)
SE7656B5045B	BACnet roof top controller	Yes	Yes	2H/2C	No	No	BACnet
SE7656B5045E	LON roof top controller	Yes	Yes	2H/2C	No	No	LonWorks
SE7656B5045P	ZigBee Pro wireless roof top controller	Yes	Yes	2H/2C	No	No	ZigBee Pro
SE7656B5045W	Wireless roof top controller	Yes	Yes	2H/2C	No	No	Wireless
SE7656B5545	Stand-alone roof top controller	Yes	Yes	2H/2C	No	Yes	Stand-alone (network ready)
SE7656B5545B	BACnet roof top controller	Yes	Yes	2H/2C	No	Yes	BACnet
SE7656B5545E	LON roof top controller	Yes	Yes	2H/2C	No	Yes	LonWorks
SE7656B5545P	ZigBee Pro wireless roof top controller	Yes	Yes	2H/2C	No	Yes	ZigBee Pro
SE7656B5545W	Wireless roof top controller	Yes	Yes	2H/2C	No	Yes	Wireless
SE7657B5045	Stand-alone roof top controller	Yes	No	2H/2C	Yes	No	Stand-alone (network ready)
SE7657B5045B	BACnet roof top controller	Yes	No	2H/2C	Yes	No	BACnet
SE7657B5045E	LON roof top controller	Yes	No	2H/2C	Yes	No	LonWorks
SE7657B5045P	ZigBee Pro wireless roof top controller	Yes	No	2H/2C	Yes	No	ZigBee Pro
SE7657B5045W	Wireless roof top controller	Yes	No	2H/2C	Yes	No	Wireless
SE7657B5545	Stand-alone roof top controller	Yes	No	2H/2C	Yes	Yes	Stand-alone (network ready)
SE7657B5545B	BACnet roof top controller	Yes	No	2H/2C	Yes	Yes	BACnet
SE7657B5545E	LON roof top controller	Yes	No	2H/2C	Yes	Yes	LonWorks
SE7657B5545P	ZigBee Pro wireless roof top controller	Yes	No	2H/2C	Yes	Yes	ZigBee Pro
SE7657B5545W	Wireless roof top controller	Yes	No	2H/2C	Yes	Yes	Wireless

SE7600H | Heat pump controllers

Part Number	Description	Scheduling	Heat/Cool Stages	PIR Cover	Communication
SE7600H5045	Stand-alone heat pump controller	No	3H/2C	No	Stand-alone (network ready)
SE7600H5045B	BACnet heat pump controller	No	3H/2C	No	BACnet
SE7600H5045E	LON heat pump controller	No	3H/2C	No	LonWorks
SE7600H5045P	ZigBee Pro Wireless heat pump controller	No	3H/2C	No	ZigBee Pro
SE7600H5045W	Wireless heat pump controller	No	3H/2C	No	Wireless
SE7600H5545	Stand-alone heat pump controller	No	3H/2C	Yes	Stand-alone (network ready)
SE7600H5545B	BACnet heat pump controller	No	3H/2C	Yes	BACnet
SE7600H5545E	LON heat pump controller	No	3H/2C	Yes	LonWorks
SE7600H5545P	ZigBee Pro Wireless heat pump controller	No	3H/2C	Yes	ZigBee Pro
SE7600H5545W	Wireless heat pump controller	No	3H/2C	Yes	Wireless
SE7652H5045	Stand-alone heat pump controller	Yes	3H/2C	No	Stand-alone (network ready)
SE7652H5045B	BACnet heat pump controller	Yes	3H/2C	No	BACnet
SE7652H5045E	LON heat pump controller	Yes	3H/2C	No	LonWorks
SE7652H5045P	ZigBee Pro Wireless heat pump controller	Yes	3H/2C	No	ZigBee Pro
SE7652H5045W	Wireless heat pump controller	Yes	3H/2C	No	Wireless
SE7652H5545	Stand-alone heat pump controller	Yes	3H/2C	Yes	Stand-alone (network ready)
SE7652H5545B	BACnet heat pump controller	Yes	3H/2C	Yes	BACnet
SE7652H5545E	LON heat pump controller	Yes	3H/2C	Yes	LonWorks
SE7652H5545P	ZigBee Pro Wireless heat pump controller	Yes	3H/2C	Yes	ZigBee Pro
SE7652H5545W	Wireless heat pump controller	Yes	3H/2C	Yes	Wireless



Management
Fundamentals of Availability
Physical Infrastructure Management Basics

Comfortable workers are more productive.

Accelerate your return on investment with SE7000 Series room controllers.



Products

Heating only: Analogue valve actuator	B-2
Cooling only: Analogue valve actuator	B-4
Heating with reheat: Analogue duct heater and electric perimeter	B-6
Heating with reheat: One stage duct heater and electric perimeter	B-8
Heating with reheat: Analogue floor radiant heat and electric perimeter	B-10
Heating with reheat: Tri-state floating valve actuator, on/off duct heater	B-12
Heating with reheat: Modulating duct heater, electric perimeter	B-14
Heating & cooling with changeover sensor & reheat: Analogue valve actuator, on/off duct heater & water sensor for changeover	B-16
Heating & cooling, changeover sensor & reheat: Tri-state floating actuator, on/off duct heater, water sensor for changeover	B-18
Heating & cooling with changeover sensor & reheat: Analogue 0-10Vdc air damper actuator, on/off duct heater and supply air sensor for changeover	B-20
Heating & cooling with changeover sensor & reheat: Floating air damper actuator, on/off duct heater and supply air sensor for changeover	B-22
Heating and cooling with reheat: Analogue 0-10Vdc air damper actuator, analogue duct heater and electric perimeter	B-24

SE7200F5045

Heating only: Analogue valve actuator

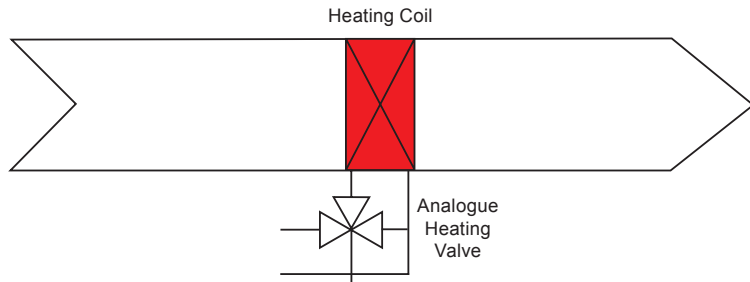

To enter configuration menu, press and hold the Override key for 8 seconds. For a full explanation of parameters, refer to Schneider installation manual.



Bill of materials (Refer to Schneider Products catalogue for more details about Schneider parts.)
Controller: Schneider SE7200F5045

Parameter	Configuration Settings
PswrdSet	0 is factory set, range is: 0-1000
BI1	None
BI2	None
UI3	None
MenuScro	On or Off if scrolling of controller status is desired
Lockout	0 = occupied setpoints and unoccupied override access
Out1Conf	2.0 = access all sequences of operation from 0 to 3
SeqOpera	1 = Heating Only
St-By TM	0.5 hours is factory set, range is: 0.0 to 24.0 hours in 0.5hr increments
Unocc TM	0.0 hours is factory set, range is: 0.0 to 24.0 hours in 0.5hr increments
St-By HT	69 °F (20.6 °C) is factory set, range is: 40 to 90 °F (4.5 to 32.0 °C)
St-By CL	78 °F (25.6 °C) is factory set, range is: 54 to 100 °F (12.0 to 37.5 °C)
Unocc HT	62 °F (16.7 °C) is factory set, range is: 40 to 90 °F (4.5 to 32.0 °C)
Unocc CL	80 °F (26.7 °C) is factory set, range is: 54 to 100 °F (12.0 to 37.5 °C)
heat max	90 °F (32.2 °C) is factory set, range is: 40 to 90 °F (4.5 to 32.0 °C)
cool min	54 °F (12.2 °C) is factory set, range is: 54 to 100 °F (12.0 to 37.5 °C)
Pband	3 °F (1.2 °C) is factory set, range is: 2 to 10 °F (0.6 to 5.6 °C)
Set Type	Permnet: (permanent) or Temporar: (temporary) setpoints
TOccTime	2 hours is factory set, range is 0 to 24 hours
DoorTime	2 minutes is factory set, range is 1 to 10 minutes (not used)
Deadband	2 °F (1 °C) is factory set, range is: 2 to 5 °F (1.0 to 2.5 °C)
cal RS	Factory set
aux cont	0, None
RA/DA	Reverse Acting (RA) or Direct Acting (DA), depends on actuator
Reheat	0 (default value)
UI3 dis	Displays supply air temperature

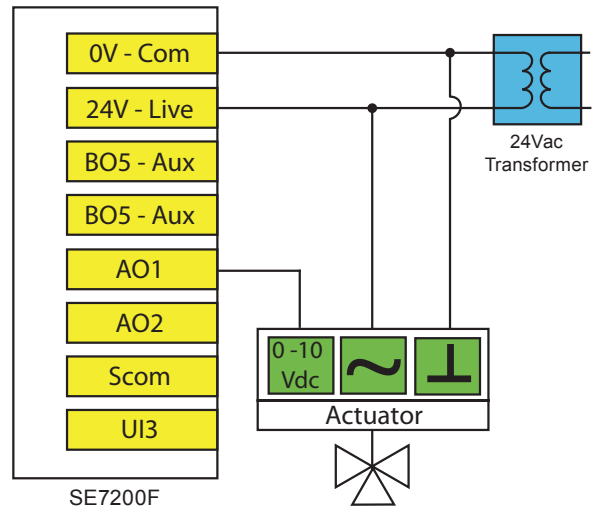

Sequence of Operation and Wiring

Occupied mode:

During occupied periods, the occupied heating and cooling setpoints are used.

PIR activated stand-by and unoccupied modes: When equipped with a PIR (Passive Infrared) accessory cover the controller provides advanced active occupancy logic, which will automatically switch occupancy levels from occupied to stand-by to unoccupied when no motion is detected in the room:

- During PIR activated stand-by periods, the stand-by heating and cooling setpoints are used.
- During PIR activated unoccupied periods, the unoccupied-by heating and cooling setpoints are used.

Unoccupied mode:

During unoccupied periods, the unoccupied heating and cooling setpoints are used.

Occupied override mode:

The controller will revert back to the occupied mode as specified by a configuration timer when a local override is requested at the controller.

On a call for heat:

The heating valve will modulate from closed to open according to the demand.

Options

BACnet, Echelon and Wireless models are available. See Appendix B for details.

Remote wall mounted sensor or a return air temperature sensor can be used instead of the internal temperature sensor of the controller.

On-Off control or 3 point floating control operation can be accomplished by using other models.

2 binary inputs and one universal input can be used and configured for advanced functionality as required by the application; e.g., discharge air sensor, door or window contact input, filter and service alarms, etc.

Auxiliary electric reheat can be added if required by the application.

SE7200F5045

Cooling only: Analogue valve actuator

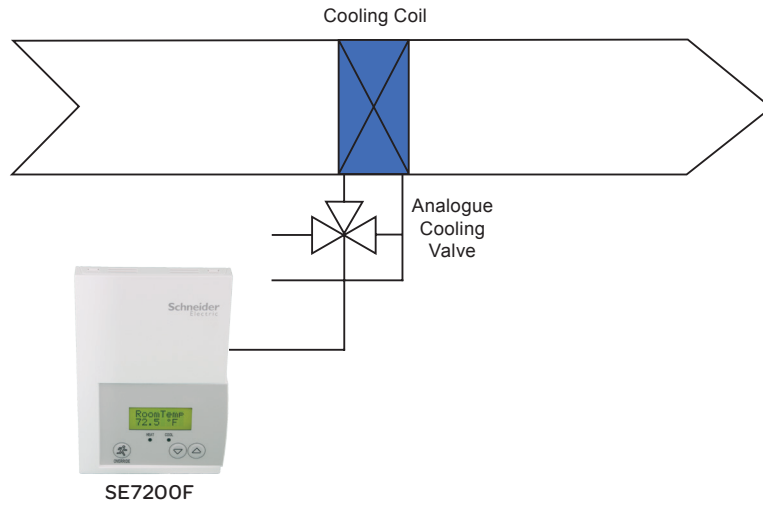

To enter configuration menu, press and hold the Override key for 8 seconds. For a full explanation of parameters, refer to Schneider installation manual.

Bill of materials (Refer to Schneider Products catalogue for more details about Schneider parts.)
Controller: Schneider SE7200F5045

Parameter	Configuration Settings
PswrdSet	0 is factory set, range is: 0-1000
BI1	None
BI2	None
UI3	None
MenuScro	On or Off if scrolling of controller status is desired
Lockout	0 = occupied setpoints and unoccupied override access
Out1Conf	2.0 = access all sequences of operation from 0 to 3
SeqOpera	0 = Cooling Only
St-By TM	0.5 hours is factory set, range is: 0.0 to 24.0 hours in 0.5hr increments
Unocc TM	0.0 hours is factory set, range is: 0.0 to 24.0 hours in 0.5hr increments
St-By HT	69 °F (20.6 °C) is factory set, range is: 40 to 90 °F (4.5 to 32.0 °C)
St-By CL	78 °F (25.6 °C) is factory set, range is: 54 to 100 °F (12.0 to 37.5 °C)
Unocc HT	62 °F (16.7 °C) is factory set, range is: 40 to 90 °F (4.5 to 32.0 °C)
Unocc CL	80 °F (26.7 °C) is factory set, range is: 54 to 100 °F (12.0 to 37.5 °C)
heat max	90 °F (32.2 °C) is factory set, range is: 40 to 90 °F (4.5 to 32.0 °C)
cool min	54 °F (12.2 °C) is factory set, range is: 54 to 100 °F (12.0 to 37.5 °C)
Pband	3 °F (1.2 °C) is factory set, range is: 2 to 10 °F (0.6 to 5.6 °C)
Set Type	Permnet: (permanent) or Temporar: (temporary) setpoints
TOccTime	2 hours is factory set, range is 0 to 24 hours
DoorTime	2 minutes is factory set, range is 1 to 10 minutes (not used)
deadband	2 °F (1 °C) is factory set, range is: 2 to 5 °F (1.0 to 2.5 °C)
cal RS	Factory set
aux cont	0, used for reheat
RA/DA	Reverse Acting (RA) or Direct Acting (DA), depends on actuator
Reheat	0 (default value)
UI3 dis	Displays supply air temperature

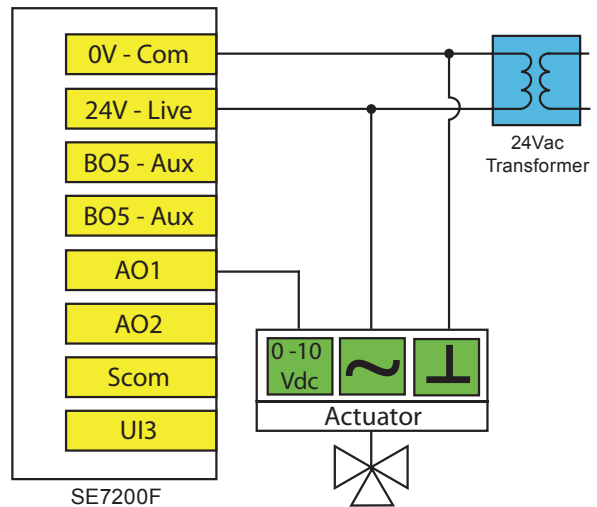

Sequence of Operation and Wiring

Occupied mode:

During occupied periods, the occupied heating and cooling setpoints are used.

PIR activated stand-by and unoccupied modes: When equipped with a PIR (Passive Infrared) accessory cover the controller provides advanced active occupancy logic, which will automatically switch occupancy levels from occupied to stand-by to unoccupied when no motion is detected in the room:

- During PIR activated stand-by periods, the stand-by heating and cooling setpoints are used.
- During PIR activated unoccupied periods, the unoccupied-by heating and cooling setpoints are used.

Unoccupied mode:

During unoccupied periods, the unoccupied heating and cooling setpoints are used.

Occupied override mode:

The controller will revert back to the occupied mode as specified by a configuration timer when a local override is requested at the controller.

On a call for cooling:

The cooling valve will modulate from closed to open according to the demand.

Options

BACnet, Echelon and Wireless models are available. See Appendix B for details.

Remote wall mounted sensor or a return air temperature sensor can be used instead of the internal temperature sensor of the controller.

On-Off control or 3 point floating control operation can be accomplished by using other models.

2 binary inputs and one universal input can be used and configured for advanced functionality as required by the application; e.g., discharge air sensor, door or window contact input, filter and service alarms, etc.

Auxiliary electric reheat can be added if required by the application.

SE7200F5045

Heating with reheat: Analogue duct heater and electric perimeter

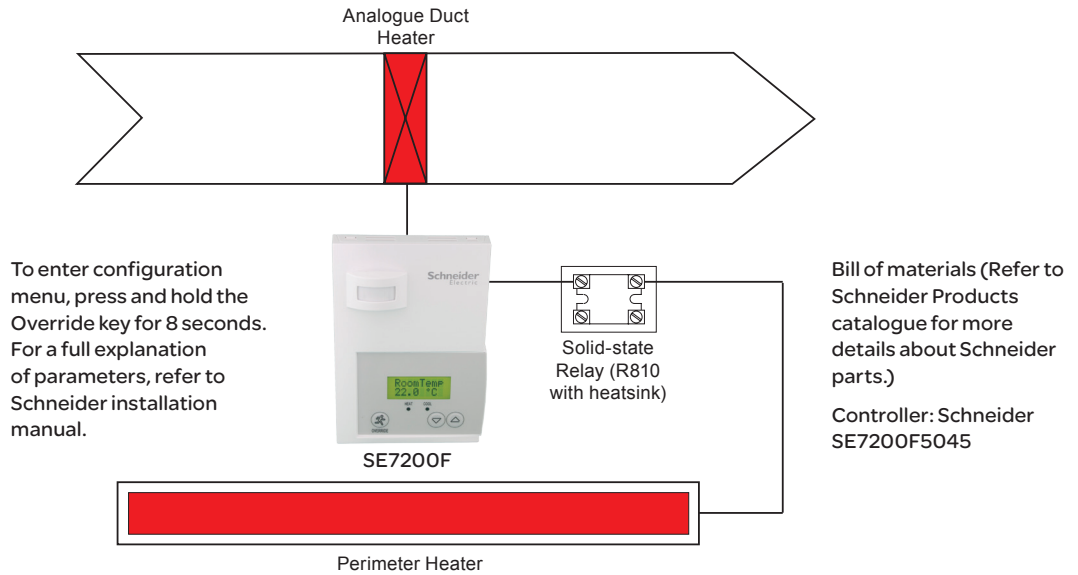

Parameter	Configuration Settings
PswrdSet	0 is factory set, range is: 0-1000
BI1	None
BI2	None
UI3	None
MenuScro	On or Off if scrolling of controller status is desired
Lockout	0 = occupied setpoints and unoccupied override access
Out1Conf	2.0 = access all sequences of operation from 0 to 3
SeqOpera	3 = Heating with reheat
St-By TM	0.5 hours is factory set, range is: 0.0 to 24.0 hours in 0.5hr increments
Unocc TM	0.0 hours is factory set, range is: 0.0 to 24.0 hours in 0.5hr increments
St-By HT	69 °F (20.6 °C) is factory set, range is: 40 to 90 °F (4.5 to 32.0 °C)
St-By CL	78 °F (25.6 °C) is factory set, range is: 54 to 100 °F (12.0 to 37.5 °C)
Unocc HT	62 °F (16.7 °C) is factory set, range is: 40 to 90 °F (4.5 to 32.0 °C)
Unocc CL	80 °F (26.7 °C) is factory set, range is: 54 to 100 °F (12.0 to 37.5 °C)
heat max	90 °F (32.2 °C) is factory set, range is: 40 to 90 °F (4.5 to 32.0 °C)
cool min	54 °F (12.2 °C) is factory set, range is: 54 to 100 °F (12.0 to 37.5 °C)
Pband	3 °F (1.2 °C) is factory set, range is: 2 to 10 °F (0.6 to 5.6 °C)
Set Type	Permnet: (permanent) or Temporar: (temporary) setpoints
TOccTime	2 hours is factory set, range is 0 to 24 hours
DoorTime	2 minutes is factory set, range is 1 to 10 minutes (not used)
Deadband	2 °F (1 °C) is factory set, range is: 2 to 5 °F (1.0 to 2.5 °C)
cal RS	Factory set
aux cont	0, reheat
RA/DA	Reverse Acting (RA) or Direct Acting (DA), depends on actuator
Reheat	1 = 10 seconds
UI3 dis	Displays supply air temperature

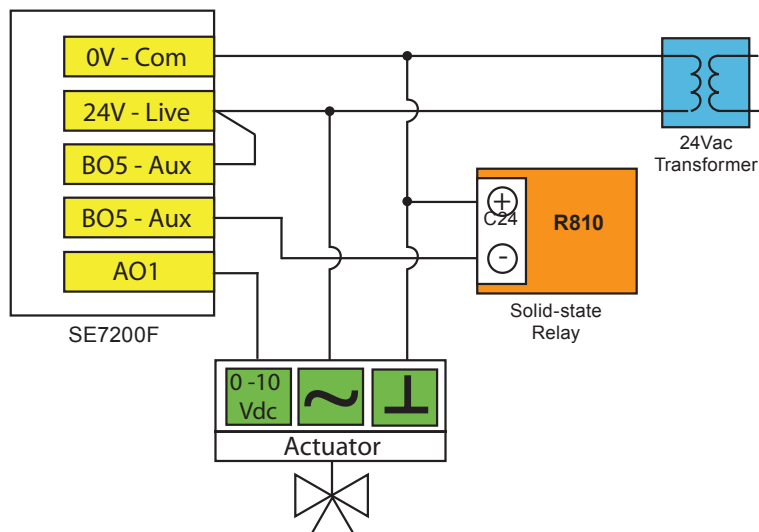

Sequence of Operation and Wiring

Occupied mode:

During occupied periods, the occupied heating and cooling setpoints are used.

PIR activated stand-by and unoccupied modes: When equipped with a PIR (Passive Infrared) accessory cover the controller provides advanced active occupancy logic, which will automatically switch occupancy levels from occupied to stand-by to unoccupied when no motion is detected in the room:

- During PIR activated stand-by periods, the stand-by heating and cooling setpoints are used.
- During PIR activated unoccupied periods, the unoccupied-by heating and cooling setpoints are used.

Unoccupied mode:

During unoccupied periods, the unoccupied heating and cooling setpoints are used.

Occupied override mode:

The controller will revert back to the occupied mode as specified by a configuration timer when a local override is requested at the controller.

On a call for heating:

The proportional device will act as a first step and modulate from 0 to 100% capacity. The perimeter heater will operate as a second step.

Options

BACnet, Echelon and Wireless models are available. See Appendix B for details.

Remote wall mounted sensor or a return air temperature sensor can be used instead of the internal temperature sensor of the controller.

On-Off control or 3 point floating control operation can be accomplished by using other models.

2 binary inputs and one universal input can be used and configured for advanced functionality as required by the application; e.g., discharge air sensor, door or window contact input, filter and service alarms, etc.

SE7200C5045

Heating with reheat: One-stage duct heater and electric perimeter

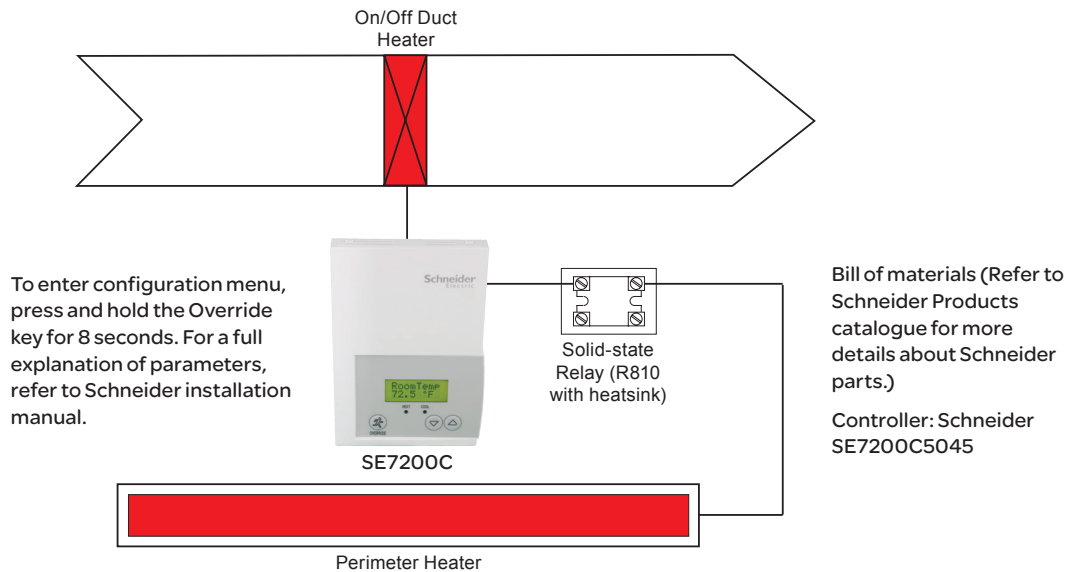

Parameter	Configuration Settings
PswrdSet	0 is factory set, range is: 0-1000
BI1	None
BI2	None
UI3	None
MenuScro	On or Off if scrolling of controller status is desired
C or F	°F or °C default value at controller power up
Lockout	0 = occupied setpoints and unoccupied override access
Out1Conf	2.0 = access all sequences of operation from 0 to 3
CntrlTyp	ON/OFF
SeqOpera	3 = Heating with Reheat
St-By TM	0.5 hours is factory set, range is: 0.0 to 24.0 hours in 0.5hr increments
Unocc TM	0.0 hours is factory set, range is: 0.0 to 24.0 hours in 0.5hr increments
St-By HT	69 °F (20.6 °C) is factory set, range is: 40 to 90 °F (4.5 to 32.0 °C)
St-By CL	78 °F (25.6 °C) is factory set, range is: 54 to 100 °F (12.0 to 37.5 °C)
Unocc HT	62 °F (16.7 °C) is factory set, range is: 40 to 90 °F (4.5 to 32.0 °C)
Unocc CL	80 °F (26.7 °C) is factory set, range is: 54 to 100 °F (12.0 to 37.5 °C)
heat max	90 °F (32.2 °C) is factory set, range is: 40 to 90 °F (4.5 to 32.0 °C)
cool min	54 °F (12.2 °C) is factory set, range is: 54 to 100 °F (12.0 to 37.5 °C)
Pband	3 °F (1.2 °C) is factory set, range is: 2 to 10 °F (0.6 to 5.6 °C)
Set Type	Permnet: (permanent) or Temporar: (temporary) setpoints
TOccTime	2 hours is factory set, range is 0 to 24 hours
DoorTime	2 minutes is factory set, range is 1 to 10 minutes (not used)
deadband	2 °F (1 °C) is factory set, range is: 2 to 5 °F (1.0 to 2.5 °C)
cal RS	Factory set
aux cont	0, used for reheat
FL time	1.5 minutes is factory set, range is 0.5 to 9 minutes
cph	3, 4, 5, 6, 7, or 8 CPH
Reheat	1= 10 seconds for Solid state relays (0 = 4 C.P.H. ON/OFF)
UI3 dis	Displays supply air temperature

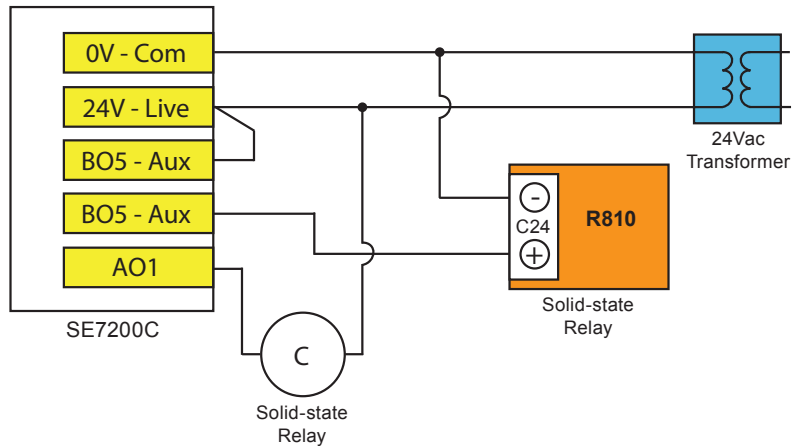

Sequence of Operation and Wiring

Occupied mode:

During occupied periods, the occupied heating and cooling setpoints are used.

PIR activated stand-by and unoccupied modes: When equipped with a PIR (Passive Infrared) accessory cover the controller provides advanced active occupancy logic, which will automatically switch occupancy levels from occupied to stand-by to unoccupied when no motion is detected in the room:

- During PIR activated stand-by periods, the stand-by heating and cooling setpoints are used.
- During PIR activated unoccupied periods, the unoccupied-by heating and cooling setpoints are used.

Unoccupied mode:

During unoccupied periods, the unoccupied heating and cooling setpoints are used.

Occupied override mode:

The controller will revert back to the occupied mode as specified by a configuration timer when a local override is requested at the controller.

On a call for heating:

The proportional device will act as a first step and modulate from 0 to 100% capacity. The perimeter heater will operate as a second step.

Options

BACnet, Echelon and Wireless models are available. See Appendix B for details.

Remote wall mounted sensor or a return air temperature sensor can be used instead of the internal temperature sensor of the controller.

2 binary inputs and one universal input can be used and configured for advanced functionality as required by the application; e.g., discharge air sensor, door or window contact input, filter and service alarms, etc.

SE7200F5045

Heating with reheat: Analogue floor radiant heat and electric perimeter

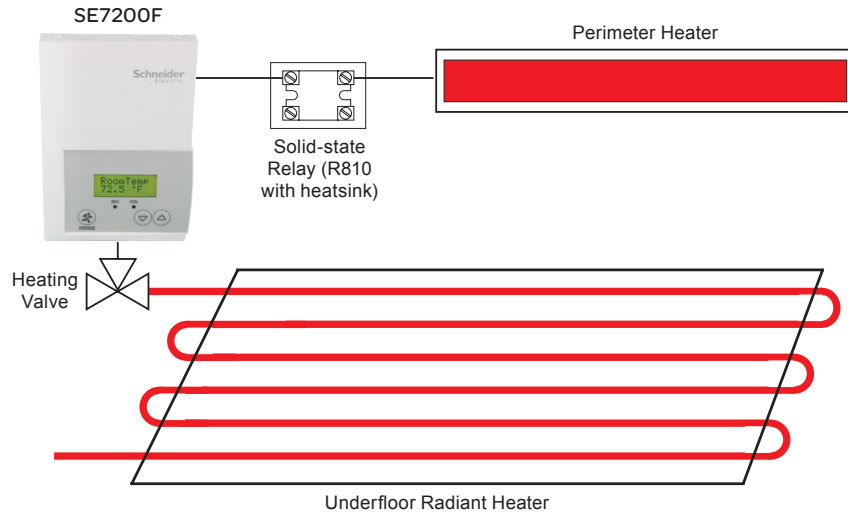

To enter configuration menu, press and hold the Override key for 8 seconds. For a full explanation of parameters, refer to Schneider installation manual.

Bill of materials (Refer to Schneider Products catalogue for details about Schneider parts.)
Controller: Schneider SE7200F5045

Parameter	Configuration Settings
PswrdSet	0 is factory set, range is: 0-1000
BI1	None
BI2	None
UI3	None
MenuScro	On or Off if scrolling of controller status is desired
Lockout	0 = occupied setpoints and unoccupied override access
Out1Conf	2.0 = access all sequences of operation from 0 to 3
SeqOpera	3 = Heating with reheat
St-By TM	0.5 hours is factory set, range is: 0.0 to 24.0 hours in 0.5hr increments
Unocc TM	0.0 hours is factory set, range is: 0.0 to 24.0 hours in 0.5hr increments
St-By HT	69 °F (20.6 °C) is factory set, range is: 40 to 90 °F (4.5 to 32.0 °C)
St-By CL	78 °F (25.6 °C) is factory set, range is: 54 to 100 °F (12.0 to 37.5 °C)
Unocc HT	62 °F (16.7 °C) is factory set, range is: 40 to 90 °F (4.5 to 32.0 °C)
Unocc CL	80 °F (26.7 °C) is factory set, range is: 54 to 100 °F (12.0 to 37.5 °C)
heat max	90 °F (32.2 °C) is factory set, range is: 40 to 90 °F (4.5 to 32.0 °C)
cool min	54 °F (12.2 °C) is factory set, range is: 54 to 100 °F (12.0 to 37.5 °C)
Pband	3 °F (1.2 °C) is factory set, range is: 2 to 10 °F (0.6 to 5.6 °C)
Set Type	Permnet: (permanent) or Temporar: (temporary) setpoints
TOccTime	2 hours is factory set, range is 0 to 24 hours
DoorTime	2 minutes is factory set, range is 1 to 10 minutes (not used)
deadband	2 °F (1 °C) is factory set, range is: 2 to 5 °F (1.0 to 2.5 °C)
cal RS	Factory set
aux cont	0, reheat
RA/DA	Reverse Acting (RA) or Direct Acting (DA), depends on actuator
Reheat	1 = 10 seconds
UI3 dis	Displays supply air temperature

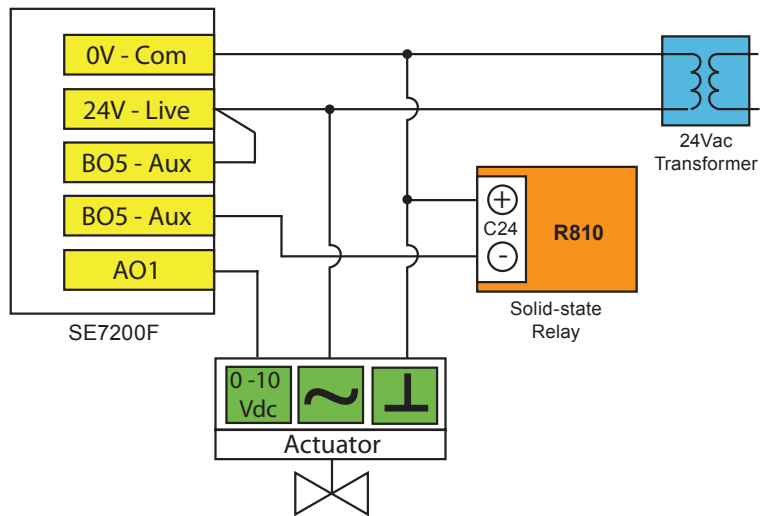

Sequence of Operation and Wiring

Occupied mode:

During occupied periods, the occupied heating and cooling setpoints are used.

PIR activated stand-by and unoccupied modes: When equipped with a PIR (Passive Infrared) accessory cover the controller provides advanced active occupancy logic, which will automatically switch occupancy levels from occupied to stand-by to unoccupied when no motion is detected in the room:

- During PIR activated stand-by periods, the stand-by heating and cooling setpoints are used.
- During PIR activated unoccupied periods, the unoccupied-by heating and cooling setpoints are used.

Unoccupied mode:

During unoccupied periods, the unoccupied heating and cooling setpoints are used.

Occupied override mode:

The controller will revert back to the occupied mode as specified by a configuration timer when a local override is requested at the controller.

On a call for heating:

The proportional device will act as a first step and modulate from 0 to 100% capacity. The perimeter heater will operate as a second step.

Options

BACnet, Echelon and Wireless models are available. See Appendix B for details.

Remote wall mounted sensor or a return air temperature sensor can be used instead of the internal temperature sensor of the controller.

On-Off control or 3 point floating control operation can be accomplished by using other models.

2 binary inputs and one universal input can be used and configured for advanced functionality as required by the application; e.g., discharge air sensor, door or window contact input, filter and service alarms, etc.

SE7200C5045

Heating with reheat: Tri-state floating valve actuator, on/off duct heater

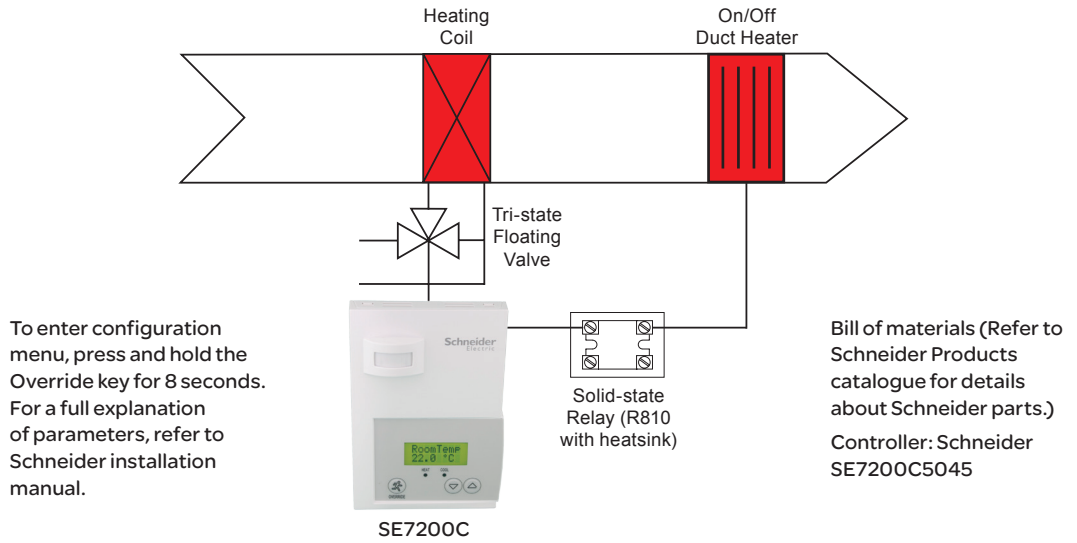

Parameter	Configuration Settings
PswrdSet	0 is factory set, range is: 0-1000
BI1	None
BI2	None
UI3	None
MenuScro	On or Off if scrolling of controller status is desired
C or F	°F or °C default value at controller power up
Lockout	0 = occupied setpoints and unoccupied override access
Out1Conf	2.0 = access all sequences of operation from 0 to 3
CntrlTyp	Floating
SeqOpera	3 = Heating with Reheat
St-By TM	0.5 hours is factory set, range is: 0.0 to 24.0 hours in 0.5hr increments
Unocc TM	0.0 hours is factory set, range is: 0.0 to 24.0 hours in 0.5hr increments
St-By HT	69 °F (20.6 °C) is factory set, range is: 40 to 90 °F (4.5 to 32.0 °C)
St-By CL	78 °F (25.6 °C) is factory set, range is: 54 to 100 °F (12.0 to 37.5 °C)
Unocc HT	62 °F (16.7 °C) is factory set, range is: 40 to 90 °F (4.5 to 32.0 °C)
Unocc CL	80 °F (26.7 °C) is factory set, range is: 54 to 100 °F (12.0 to 37.5 °C)
heat max	90 °F (32.2 °C) is factory set, range is: 40 to 90 °F (4.5 to 32.0 °C)
cool min	54 °F (12.2 °C) is factory set, range is: 54 to 100 °F (12.0 to 37.5 °C)
Pband	3 °F (1.2 °C) is factory set, range is: 2 to 10 °F (0.6 to 5.6 °C)
Set Type	Permnet: (permanent) or Temporar: (temporary) setpoints
TOccTime	2 hours is factory set, range is 0 to 24 hours
DoorTime	2 minutes is factory set, range is 1 to 10 minutes (not used)
deadband	2 °F (1 °C) is factory set, range is: 2 to 5 °F (1.0 to 2.5 °C)
cal RS	Factory set
aux cont	0, used for reheat
FL time	1.5 minutes is factory set, range is 0.5 to 9 minutes
cph	3, 4, 5, 6, 7, or 8 CPH
Reheat	0 = 4 C.P.H. ON/OFF (0 = 10 seconds for Solid state relays)
UI3 dis	Displays supply air temperature

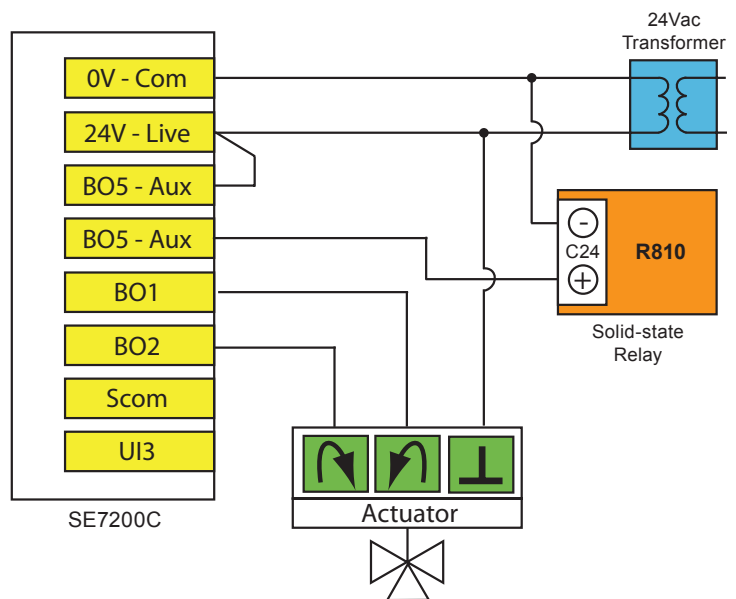

Sequence of Operation and Wiring

Occupied mode:

During occupied periods, the occupied heating and cooling setpoints are used.

PIR activated stand-by and unoccupied modes: When equipped with a PIR (Passive Infrared) accessory cover the controller provides advanced active occupancy logic, which will automatically switch occupancy levels from occupied to stand-by to unoccupied when no motion is detected in the room:

- During PIR activated stand-by periods, the stand-by heating and cooling setpoints are used.
- During PIR activated unoccupied periods, the unoccupied-by heating and cooling setpoints are used.

Unoccupied mode:

During unoccupied periods, the unoccupied heating and cooling setpoints are used.

Occupied override mode:

The controller will revert back to the occupied mode as specified by a configuration timer when a local override is requested at the controller.

On a call for heating:

The proportional device will act as a first step and modulate from 0 to 100% capacity. The duct heater will operate as a second step.

Options

BACnet, Echelon and Wireless models are available. See Appendix B for details.

Remote wall mounted sensor or a return air temperature sensor can be used instead of the internal temperature sensor of the controller.

2 binary inputs and one universal input can be used and configured for advanced functionality as required by the application; e.g., discharge air sensor, door or window contact input, filter and service alarms, etc.

SE7200F5045

Heating with reheat: Modulating duct heater, electric perimeter

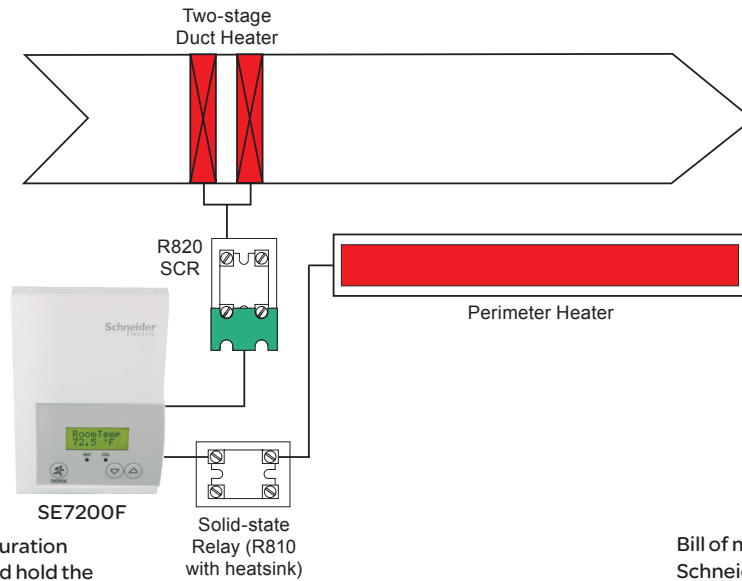

To enter configuration menu, press and hold the Override key for 8 seconds. For a full explanation of parameters, refer to Schneider installation manual.

Bill of materials (refer to Schneider Products catalogue for details about Schneider parts)
Controller: Schneider SE7200F5045

Parameter	Configuration Settings
PswrdSet	0 is factory set, range is: 0-1000
BI1	None
BI2	None
UI3	None
MenuScro	On or Off if scrolling of controller status is desired
C or F	°F or °C default value at controller power up
Lockout	0 = occupied setpoints and unoccupied override access
Out1Conf	2.0 = access all sequences of operation from 0 to 3
SeqOpera	3 = Heating with Reheat
St-By TM	0.5 hours is factory set, range is: 0.0 to 24.0 hours in 0.5hr increments
Unocc TM	0.0 hours is factory set, range is: 0.0 to 24.0 hours in 0.5hr increments
St-By HT	69 °F (20.6 °C) is factory set, range is: 40 to 90 °F (4.5 to 32.0 °C)
St-By CL	78 °F (25.6 °C) is factory set, range is: 54 to 100 °F (12.0 to 37.5 °C)
Unocc HT	62 °F (16.7 °C) is factory set, range is: 40 to 90 °F (4.5 to 32.0 °C)
Unocc CL	80 °F (26.7 °C) is factory set, range is: 54 to 100 °F (12.0 to 37.5 °C)
heat max	90 °F (32.2 °C) is factory set, range is: 40 to 90 °F (4.5 to 32.0 °C)
cool min	54 °F (12.2 °C) is factory set, range is: 54 to 100 °F (12.0 to 37.5 °C)
Pband	3 °F (1.2 °C) is factory set, range is: 2 to 10 °F (0.6 to 5.6 °C)
Set Type	Permnet: (permanent) or Temporar: (temporary) setpoints
TOccTime	2 hours is factory set, range is 0 to 24 hours
DoorTime	2 minutes is factory set, range is 1 to 10 minutes (not used)
deadband	2 °F (1 °C) is factory set, range is: 2 to 5 °F (1.0 to 2.5 °C)
cal RS	Factory set
aux cont	0, used for reheat
RA/DA	RA = reverse acting, DA = direct acting
Reheat	1= 10 seconds for Solid state relays (0 = 4 C.P.H. ON/OFF)
UI3 dis	Displays supply air temperature

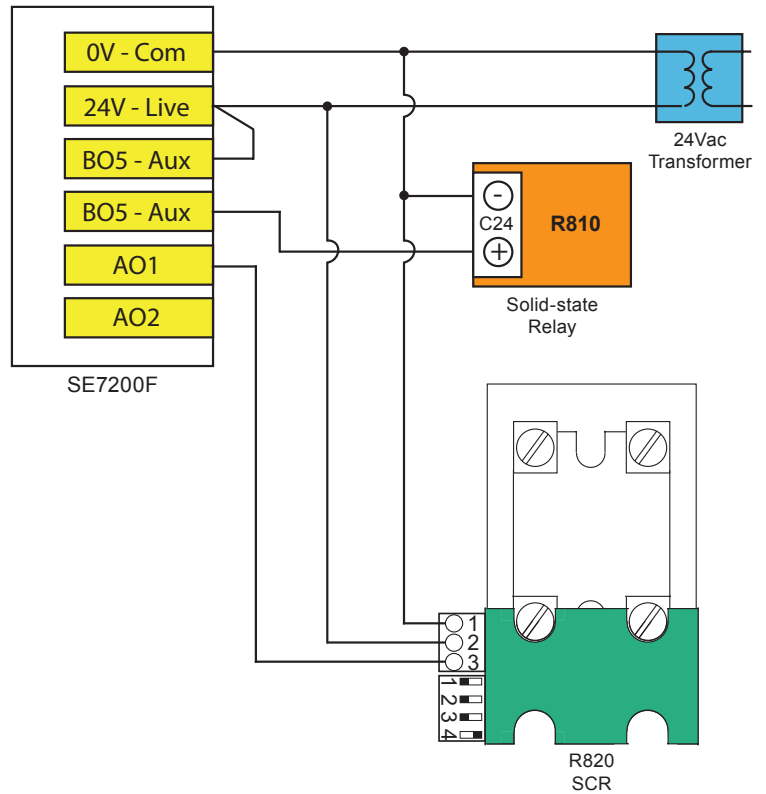

Sequence of Operation and Wiring

Occupied mode:

During occupied periods, the occupied heating and cooling setpoints are used.

PIR activated stand-by and unoccupied modes: When equipped with a PIR (Passive Infrared) accessory cover the controller provides advanced active occupancy logic, which will automatically switch occupancy levels from occupied to stand-by to unoccupied when no motion is detected in the room:

- During PIR activated stand-by periods, the stand-by heating and cooling setpoints are used.
- During PIR activated unoccupied periods, the unoccupied-by heating and cooling setpoints are used.

Unoccupied mode:

During unoccupied periods, the unoccupied heating and cooling setpoints are used.

Occupied override mode:

The controller will revert back to the occupied mode as specified by a configuration timer when a local override is requested at the controller.

On a call for heating:

The proportional device will act as a first step and modulate from 0 to 100% capacity. The perimeter heater will operate as a second step.

Options

BACnet, Echelon and Wireless models are available. See Appendix B for details.

Remote wall mounted sensor or a return air temperature sensor can be used instead of the internal temperature sensor of the controller.

2 binary inputs and one universal input can be used and configured for advanced functionality as required by the application; e.g., discharge air sensor, door or window contact input, filter and service alarms, etc.

SE7200F5045

Heating & cooling with changeover sensor & reheat: Analogue valve actuator, on/off duct heater & water sensor for changeover

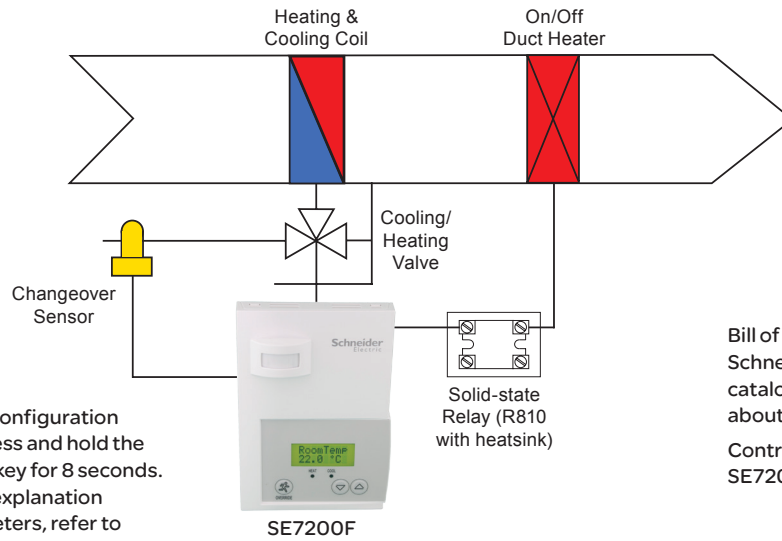

To enter configuration menu, press and hold the Override key for 8 seconds. For a full explanation of parameters, refer to Schneider installation manual.

Bill of materials (Refer to Schneider Products catalogue for details about Schneider parts.)
Controller: Schneider SE7200F5045

Parameter	Configuration Settings
PswrdSet	0 is factory set, range is: 0-1000
BI1	None
BI2	None
UI3	COS
MenuScro	On or Off if scrolling of controller status is desired
C or F	°F or °C default value at controller power up
Lockout	0 = occupied setpoints and unoccupied override access
Out1Conf	2.0 = access all sequences of operation from 0 to 3
SeqOpera	2 = Cooling with Reheat
St-By TM	0.5 hours is factory set, range is: 0.0 to 24.0 hours in 0.5hr increments
Unocc TM	0.0 hours is factory set, range is: 0.0 to 24.0 hours in 0.5hr increments
St-By HT	69 °F (20.6 °C) is factory set, range is: 40 to 90 °F (4.5 to 32.0 °C)
St-By CL	78 °F (25.6 °C) is factory set, range is: 54 to 100 °F (12.0 to 37.5 °C)
Unocc HT	62 °F (16.7 °C) is factory set, range is: 40 to 90 °F (4.5 to 32.0 °C)
Unocc CL	80 °F (26.7 °C) is factory set, range is: 54 to 100 °F (12.0 to 37.5 °C)
heat max	90 °F (32.2 °C) is factory set, range is: 40 to 90 °F (4.5 to 32.0 °C)
cool min	54 °F (12.2 °C) is factory set, range is: 54 to 100 °F (12.0 to 37.5 °C)
Pband	3 °F (1.2 °C) is factory set, range is: 2 to 10 °F (0.6 to 5.6 °C)
Set Type	Permnet: (permanent) or Temporar: (temporary) setpoints
TOccTime	2 hours is factory set, range is 0 to 24 hours
DoorTime	2 minutes is factory set, range is 1 to 10 minutes (not used)
deadband	2 °F (1 °C) is factory set, range is: 2 to 5 °F (1.0 to 2.5 °C)
cal RS	Factory set
aux cont	0, used for reheat
RA/DA	Reverse Acting (RA) or Direct Acting (DA), depends on actuator
Reheat	1= 10 seconds for Solid state relays (0 = 4 C.P.H. ON/OFF)
UI3 dis	Displays supply air temperature

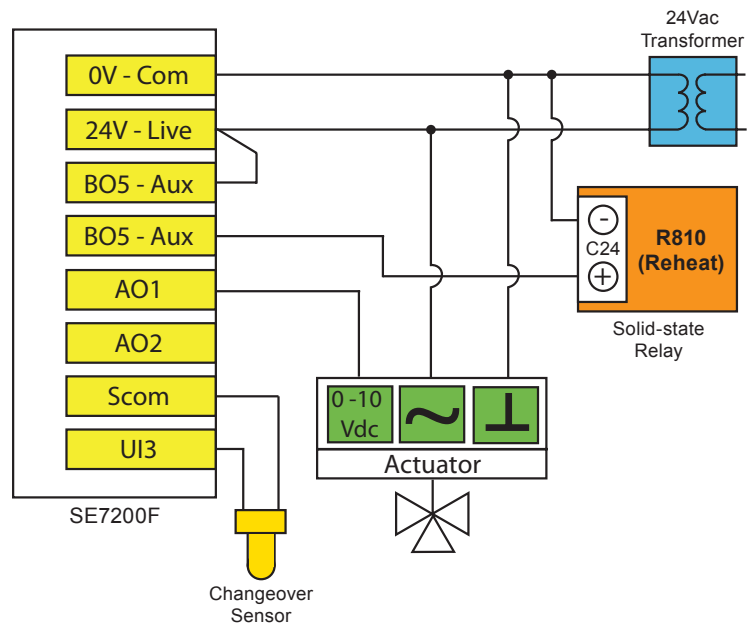

Sequence of Operation and Wiring

Occupied mode:

During occupied periods, the occupied heating and cooling setpoints are used.

PIR activated stand-by and unoccupied modes: When equipped with a PIR (Passive Infrared) accessory cover the controller provides advanced active occupancy logic, which will automatically switch occupancy levels from occupied to stand-by to unoccupied when no motion is detected in the room:

- During PIR activated stand-by periods, the stand-by heating and cooling setpoints are used.
- During PIR activated unoccupied periods, the unoccupied-by heating and cooling setpoints are used.

Unoccupied mode:

During unoccupied periods, the unoccupied heating and cooling setpoints are used.

Occupied override mode:

The controller will revert back to the occupied mode as specified by a configuration timer when a local override is requested at the controller.

On a call for cooling:

If the supply water temperature is less than 75°F (23.9°C), the valve will modulate from closed to open according to demand. If the water supply temperature is greater than 77°F (25°C), the valve will remain closed.

On a call for heating:

If the supply water temperature is higher than 77°F (25°C), the valve will modulate from closed to open according to demand. If the water supply temperature is less than 75°F (23.9°C), the valve will remain closed. The duct heater will operate as a second step.

Options

BACnet, Echelon and Wireless models are available. See Appendix B for details.

Remote wall mounted sensor or a return air temperature sensor can be used instead of the internal temperature sensor of the controller.

On-Off control or 3 point floating control operation can be accomplished by using other models.

2 binary inputs and one universal input can be used and configured for advanced functionality as required by the application; e.g., discharge air sensor, door or window contact input, filter and service alarms, etc.

SE7200C5045

Heating & cooling, changeover sensor & reheat:
Tri-state floating actuator, on/off duct heater,
water sensor for changeover

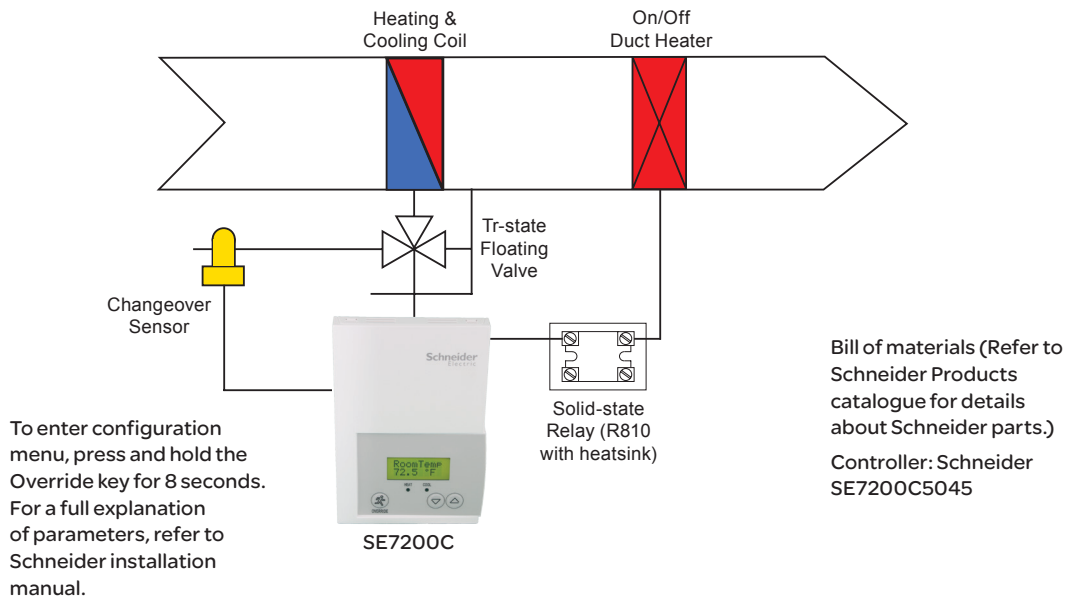

Parameter	Configuration Settings
PswrdSet	0 is factory set, range is: 0-1000
BI1	None
BI2	None
UI3	COS
MenuScro	On or Off if scrolling of controller status is desired
C or F	°F or °C default value at controller power up
Lockout	0 = occupied setpoints and unoccupied override access
Out1Conf	2.0 = access all sequences of operation from 0 to 3
CntrlTyp	Floating
SeqOpera	2 = Cooling with Reheat
St-By TM	0.5 hours is factory set, range is: 0.0 to 24.0 hours in 0.5hr increments
Unocc TM	0.0 hours is factory set, range is: 0.0 to 24.0 hours in 0.5hr increments
St-By HT	69 °F (20.6 °C) is factory set, range is: 40 to 90 °F (4.5 to 32.0 °C)
St-By CL	78 °F (25.6 °C) is factory set, range is: 54 to 100 °F (12.0 to 37.5 °C)
Unocc HT	62 °F (16.7 °C) is factory set, range is: 40 to 90 °F (4.5 to 32.0 °C)
Unocc CL	80 °F (26.7 °C) is factory set, range is: 54 to 100 °F (12.0 to 37.5 °C)
heat max	90 °F (32.2 °C) is factory set, range is: 40 to 90 °F (4.5 to 32.0 °C)
cool min	54 °F (12.2 °C) is factory set, range is: 54 to 100 °F (12.0 to 37.5 °C)
Pband	3 °F (1.2 °C) is factory set, range is: 2 to 10 °F (0.6 to 5.6 °C)
Set Type	Permnet: (permanent) or Temporar: (temporary) setpoints
TOccTime	2 hours is factory set, range is 0 to 24 hours
DoorTime	2 minutes is factory set, range is 1 to 10 minutes (not used)
deadband	2 °F (1 °C) is factory set, range is: 2 to 5 °F (1.0 to 2.5 °C)
cal RS	Factory set
aux cont	0, used for reheat
FL time	1.5 minutes is factory set, range is 0.5 to 9 minutes
cph	N/A
Reheat	1= 10 seconds for Solid state relays (0 = 4 C.P.H. ON/OFF)
UI3 dis	Displays supply air temperature

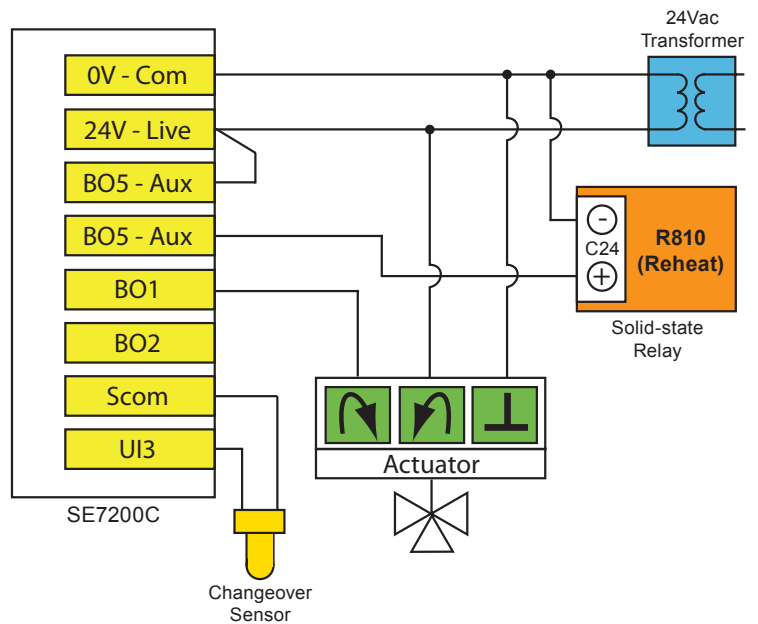

Sequence of Operation and Wiring

Occupied mode:

During occupied periods, the occupied heating and cooling setpoints are used.

PIR activated stand-by and unoccupied modes: When equipped with a PIR (Passive Infrared) accessory cover the controller provides advanced active occupancy logic, which will automatically switch occupancy levels from occupied to stand-by to unoccupied when no motion is detected in the room:

- During PIR activated stand-by periods, the stand-by heating and cooling setpoints are used.
- During PIR activated unoccupied periods, the unoccupied-by heating and cooling setpoints are used.

Unoccupied mode:

During unoccupied periods, the unoccupied heating and cooling setpoints are used.

Local override:

The controller will revert back to the occupied mode as specified by a configuration timer when a local override is requested at the controller.

On a call for cooling:

If the supply water temperature is less than 75°F (23.9°C), the valve will modulate from closed to open according to demand. If the water supply temperature is greater than 77°F (25°C), the valve will remain closed.

On a call for heating:

If the supply water temperature is higher than 77°F (25°C), the valve will modulate from closed to open according to demand. If the water supply temperature is less than 75°F (23.9°C), the valve will remain closed. The duct heater will operate as a second step.

Options

BACnet, Echelon and Wireless models are available. See Appendix B for details.

Remote wall mounted sensor or a return air temperature sensor can be used instead of the internal temperature sensor of the controller.

2 binary inputs and one universal input can be used and configured for advanced functionality as required by the application; e.g., discharge air sensor, door or window contact input, filter and service alarms, etc.

SE7200F5045

Heating & cooling with changeover sensor & reheat: Analogue Damper & On/Off Duct Heater, on/off duct heater & air sensor for changeover

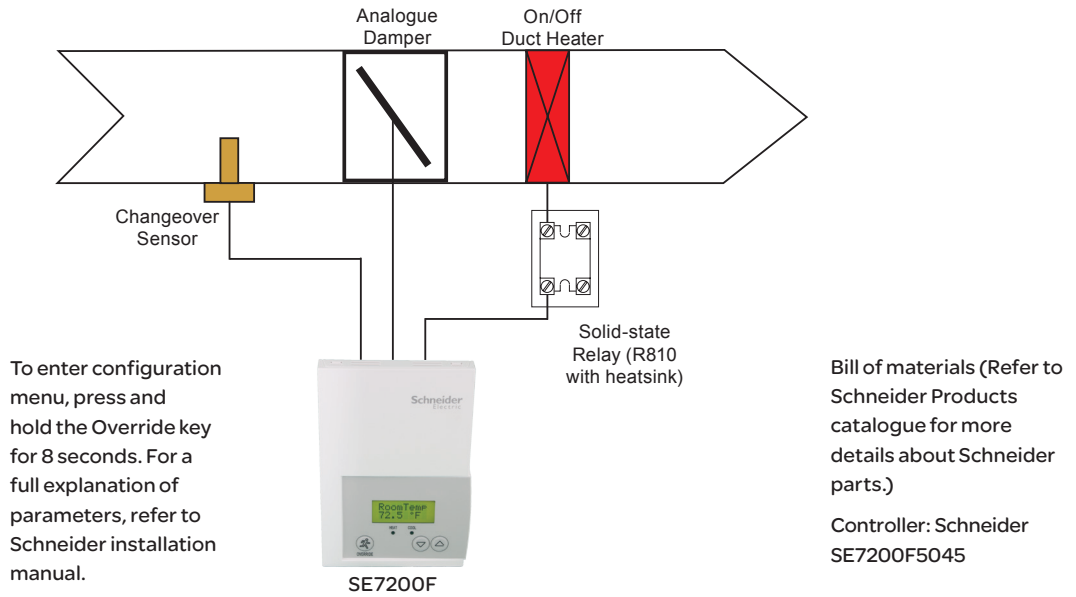

Parameter	Configuration Settings
PswrdSet	0 is factory set, range is: 0-1000
BI1	None
BI2	None
UI3	COS
MenuScro	On or Off if scrolling of controller status is desired
Lockout	0 = occupied setpoints and unoccupied override access
Out1Conf	2.0 = access all sequences of operation from 0 to 3
SeqOpera	2 = Cooling with Reheat
St-By TM	0.5 hours is factory set, range is: 0.0 to 24.0 hours in 0.5hr increments
Unocc TM	0.0 hours is factory set, range is: 0.0 to 24.0 hours in 0.5hr increments
St-By HT	69 °F (20.6 °C) is factory set, range is: 40 to 90 °F (4.5 to 32.0 °C)
St-By CL	78 °F (25.6 °C) is factory set, range is: 54 to 100 °F (12.0 to 37.5 °C)
Unocc HT	62 °F (16.7 °C) is factory set, range is: 40 to 90 °F (4.5 to 32.0 °C)
Unocc CL	80 °F (26.7 °C) is factory set, range is: 54 to 100 °F (12.0 to 37.5 °C)
heat max	90 °F (32.2 °C) is factory set, range is: 40 to 90 °F (4.5 to 32.0 °C)
cool min	54 °F (12.2 °C) is factory set, range is: 54 to 100 °F (12.0 to 37.5 °C)
Pband	3 °F (1.2 °C) is factory set, range is: 2 to 10 °F (0.6 to 5.6 °C)
Set Type	Permnt: (permanent) or Temporar: (temporary) setpoints
TOccTime	2 hours is factory set, range is 0 to 24 hours
DoorTime	2 minutes is factory set, range is 1 to 10 minutes (not used)
deadband	2 °F (1 °C) is factory set, range is: 2 to 5 °F (1.0 to 2.5 °C)
cal RS	Factory set
aux cont	0, used for reheat
RA/DA	Reverse Acting (RA) or Direct Acting (DA), depends on actuator
Reheat	1= 10 seconds for Solid state relays (0 = 4 C.P.H. ON/OFF)
UI3 dis	Displays supply air temperature

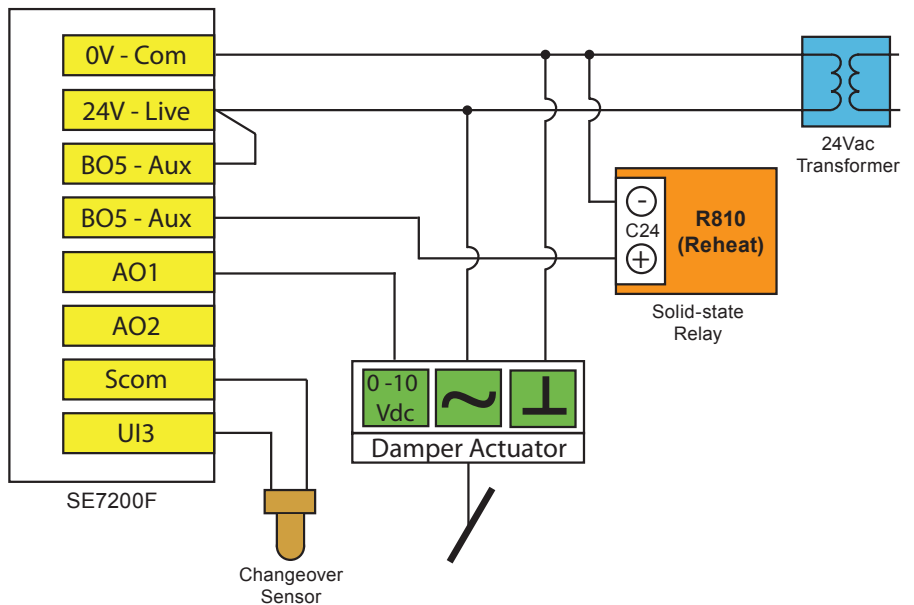

Sequence of Operation and Wiring

Occupied mode:

During occupied periods, the occupied heating and cooling setpoints are used.

PIR activated stand-by and unoccupied modes: When equipped with a PIR (Passive Infrared) accessory cover the controller provides advanced active occupancy logic, which will automatically switch occupancy levels from occupied to stand-by to unoccupied when no motion is detected in the room:

- During PIR activated stand-by periods, the stand-by heating and cooling setpoints are used.
- During PIR activated unoccupied periods, the unoccupied-by heating and cooling setpoints are used.

Unoccupied mode:

During unoccupied periods, the unoccupied heating and cooling setpoints are used.

Local override:

The controller will revert back to the occupied mode as specified by a configuration timer when a local override is requested at the controller.

On a call for heating:

If the supply water temperature is higher than 77°F (25°C), the valve will modulate from closed to open according to demand. If the water supply temperature is less than 75°F (23.9°C), the valve will remain closed. The duct heater will operate as a second step.

On a call for cooling:

If the supply air temperature is less than 75°F (23.9°C), the damper will modulate from closed to open according to demand. If the water supply temperature is greater than 77°F (25°C), the damper will remain closed.

Options

BACnet, Echelon and Wireless models are available. See Appendix B for details.

Remote wall mounted sensor or a return air temperature sensor can be used instead of the internal temperature sensor of the controller.

On-Off control or 3 point floating control operation can be accomplished by using other models.

2 binary inputs and one universal input can be used and configured for advanced functionality as required by the application; e.g., discharge air sensor, door or window contact input, filter and service alarms, etc.

SE7200C5045

Heating & cooling with changeover sensor & reheat: Floating air damper actuator, on/off duct heater and supply air sensor for changeover

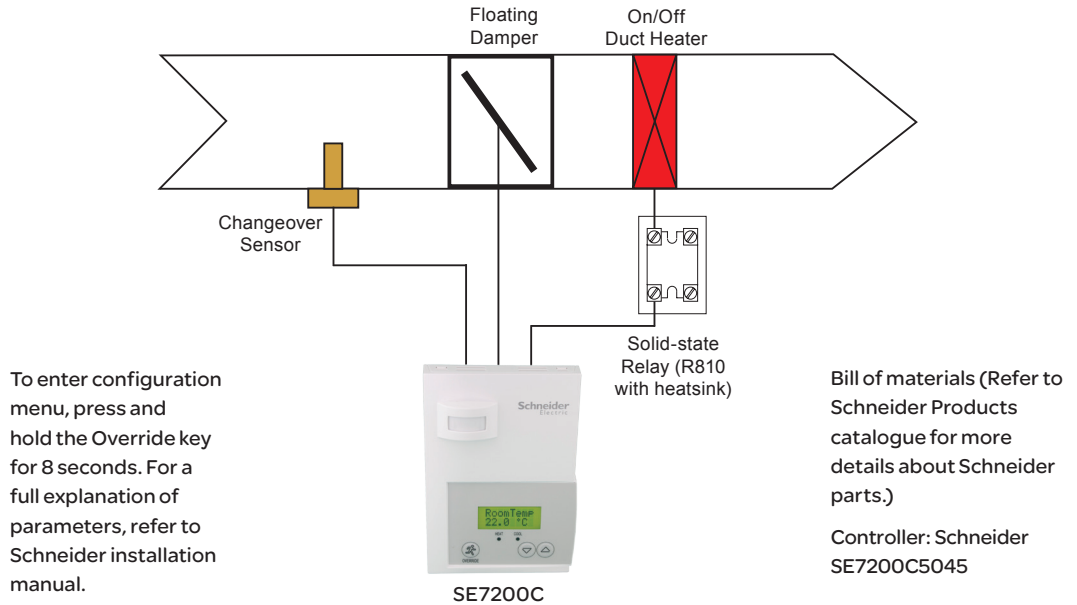

Parameter	Configuration Settings
PswrdSet	0 is factory set, range is: 0-1000
BI1	None
BI2	None
UI3	COS
MenuScro	On or Off if scrolling of controller status is desired
C or F	°F or °C default value at controller power up
Lockout	0 = occupied setpoints and unoccupied override access
Out1Conf	2.0 = access all sequences of operation from 0 to 3
CntrlTyp	Floating
SeqOpera	2 = Cooling with Reheat
St-By TM	0.5 hours is factory set, range is: 0.0 to 24.0 hours in 0.5hr increments
Unocc TM	0.0 hours is factory set, range is: 0.0 to 24.0 hours in 0.5hr increments
St-By HT	69 °F (20.6 °C) is factory set, range is: 40 to 90 °F (4.5 to 32.0 °C)
St-By CL	78 °F (25.6 °C) is factory set, range is: 54 to 100 °F (12.0 to 37.5 °C)
Unocc HT	62 °F (16.7 °C) is factory set, range is: 40 to 90 °F (4.5 to 32.0 °C)
Unocc CL	80 °F (26.7 °C) is factory set, range is: 54 to 100 °F (12.0 to 37.5 °C)
heat max	90 °F (32.2 °C) is factory set, range is: 40 to 90 °F (4.5 to 32.0 °C)
cool min	54 °F (12.2 °C) is factory set, range is: 54 to 100 °F (12.0 to 37.5 °C)
Pband	3 °F (1.2 °C) is factory set, range is: 2 to 10 °F (0.6 to 5.6 °C)
Set Type	Permnet: (permanent) or Temporar: (temporary) setpoints
TOccTime	2 hours is factory set, range is 0 to 24 hours
DoorTime	2 minutes is factory set, range is 1 to 10 minutes (not used)
deadband	2 °F (1 °C) is factory set, range is: 2 to 5 °F (1.0 to 2.5 °C)
cal RS	Factory set
aux cont	0, used for reheat
FL time	1.5 minutes is factory set, range is 0.5 to 9 minutes
cph	N/A
Reheat	1= 10 seconds for Solid state relays (0 = 4 C.P.H. ON/OFF)
UI3 dis	Displays supply air temperature

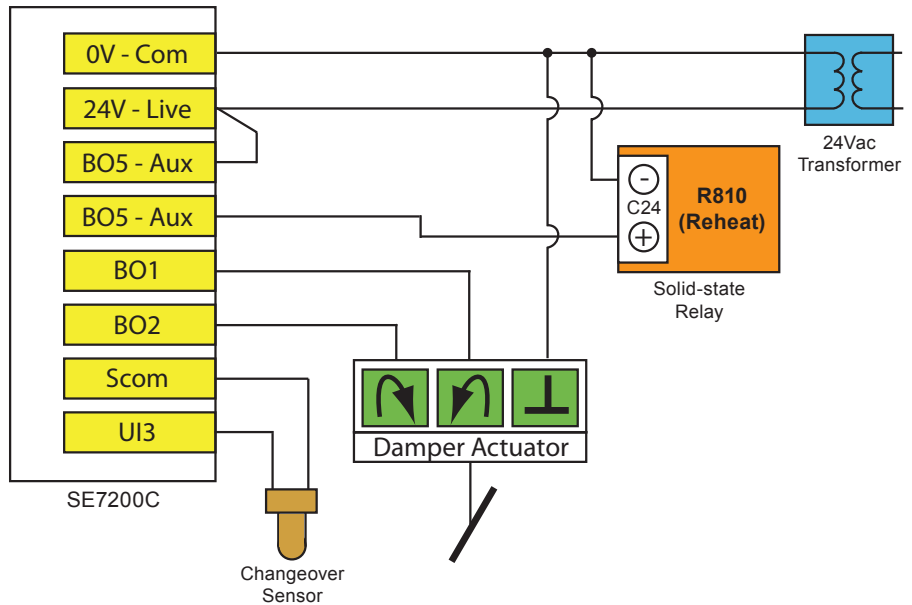

Sequence of Operation and Wiring

Occupied mode:

During occupied periods, the occupied heating and cooling setpoints are used.

PIR activated stand-by and unoccupied modes: When equipped with a PIR (Passive Infrared) accessory cover the controller provides advanced active occupancy logic, which will automatically switch occupancy levels from occupied to stand-by to unoccupied when no motion is detected in the room:

- During PIR activated stand-by periods, the stand-by heating and cooling setpoints are used.
- During PIR activated unoccupied periods, the unoccupied-by heating and cooling setpoints are used.

Unoccupied mode:

During unoccupied periods, the unoccupied heating and cooling setpoints are used.

Local override:

The controller will revert back to the occupied mode as specified by a configuration timer when a local override is requested at the controller.

On a call for heating:

If the supply water temperature is higher than 77°F (25°C), the damper will modulate from closed to open according to demand. If the water supply temperature is less than 75°F (23.9°C), the damper will remain closed. The duct heater will operate as a second step.

On a call for cooling:

If the supply air temperature is less than 75°F (23.9°C), the damper will modulate from closed to open according to demand. If the water supply temperature is greater than 77°F (25°C), the damper will remain closed.

Options

BACnet, Echelon and Wireless models are available. See Appendix B for details.

Remote wall mounted sensor or a return air temperature sensor can be used instead of the internal temperature sensor of the controller.

2 binary inputs and one universal input can be used and configured for advanced functionality as required by the application; e.g., discharge air sensor, door or window contact input, filter and service alarms, etc.

SE7200F5045

Heating and cooling with reheat: Analogue
0-10Vdc air damper actuator, analogue duct
heater and electric perimeter

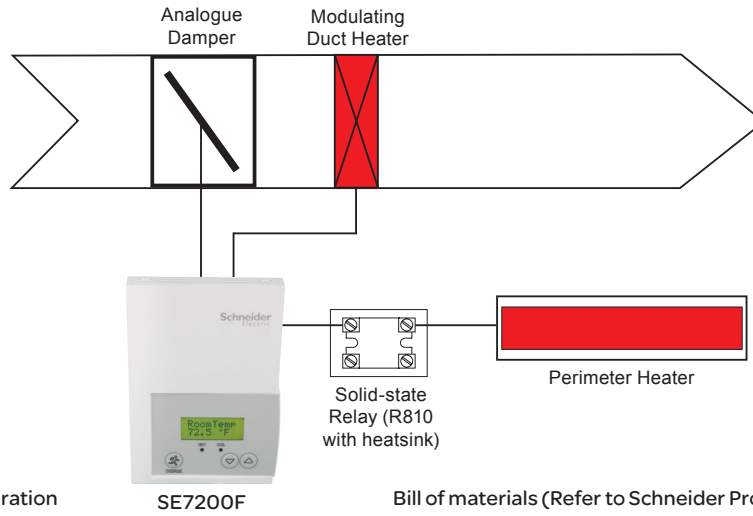

To enter configuration menu, press and hold the Override key for 8 seconds. For a full explanation of parameters, refer to Schneider installation manual.

Bill of materials (Refer to Schneider Products catalogue for more details about Schneider parts.)
Controller: Schneider SE7200F5045

Parameter	Configuration Settings
PswrdSet	0 is factory set, range is: 0-1000
BI1	None
BI2	None
UI3	COS
MenuScro	On or Off if scrolling of controller status is desired
Lockout	0 = occupied setpoints and unoccupied override access
Out1Conf	4.0 = access all sequences of operation from 0 to 3
SeqOpera	5 = Cooling and heating with Reheat
St-By TM	0.5 hours is factory set, range is: 0.0 to 24.0 hours in 0.5hr increments
Unocc TM	0.0 hours is factory set, range is: 0.0 to 24.0 hours in 0.5hr increments
St-By HT	69 °F (20.6 °C) is factory set, range is: 40 to 90 °F (4.5 to 32.0 °C)
St-By CL	78 °F (25.6 °C) is factory set, range is: 54 to 100 °F (12.0 to 37.5 °C)
Unocc HT	62 °F (16.7 °C) is factory set, range is: 40 to 90 °F (4.5 to 32.0 °C)
Unocc CL	80 °F (26.7 °C) is factory set, range is: 54 to 100 °F (12.0 to 37.5 °C)
heat max	90 °F (32.2 °C) is factory set, range is: 40 to 90 °F (4.5 to 32.0 °C)
cool min	54 °F (12.2 °C) is factory set, range is: 54 to 100 °F (12.0 to 37.5 °C)
Pband	3 °F (1.2 °C) is factory set, range is: 2 to 10 °F (0.6 to 5.6 °C)
Set Type	Permnet: (permanent) or Temporar: (temporary) setpoints
TOccTime	2 hours is factory set, range is 0 to 24 hours
DoorTime	2 minutes is factory set, range is 1 to 10 minutes (not used)
deadband	2 °F (1 °C) is factory set, range is: 2 to 5 °F (1.0 to 2.5 °C)
cal RS	Factory set
aux cont	0, used for reheat
RA/DA	Reverse Acting (RA) or Direct Acting (DA), depends on actuator
Reheat	1= 10 seconds for Solid state relays (0 = 4 C.P.H. ON/OFF)
UI3 dis	Displays supply air temperature
Reheat	1= 10 seconds for Solid state relays (0 = 4 C.P.H. ON/OFF)
UI3 dis	Displays supply air temperature

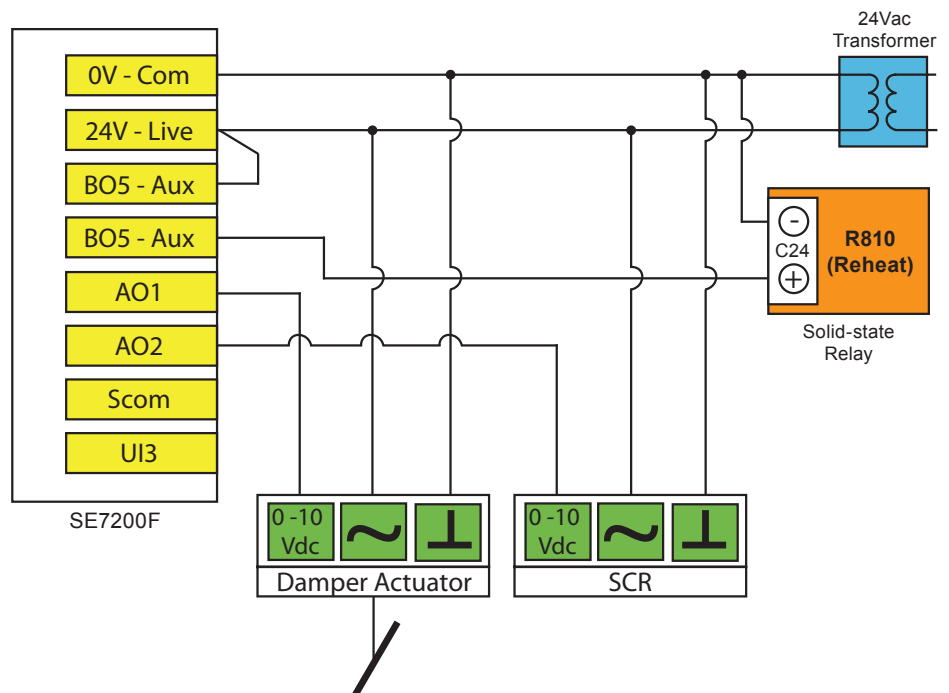

Sequence of Operation and Wiring

Occupied mode:

During occupied periods, the occupied heating and cooling setpoints are used.

PIR activated stand-by and unoccupied modes: When equipped with a PIR (Passive Infrared) accessory cover the controller provides advanced active occupancy logic, which will automatically switch occupancy levels from occupied to stand-by to unoccupied when no motion is detected in the room:

- During PIR activated stand-by periods, the stand-by heating and cooling setpoints are used.
- During PIR activated unoccupied periods, the unoccupied-by heating and cooling setpoints are used.

Unoccupied mode:

During unoccupied periods, the unoccupied heating and cooling setpoints are used.

Local override:

The controller will revert back to the occupied mode as specified by a configuration timer when a local override is requested at the controller.

On a call for heating:

The damper will remain closed. The proportional heater will act as a first step and modulate from 0 to 100% capacity. The perimeter heater will operate as a second step.

On a call for cooling:

The damper will modulate from closed to open according to demand.

Options

BACnet, Echelon and Wireless models are available. See Appendix B for details.

Remote wall mounted sensor or a return air temperature sensor can be used instead of the internal temperature sensor of the controller.

On-Off control or 3 point floating control operation can be accomplished by using other models.

2 binary inputs and one universal input can be used and configured for advanced functionality as required by the application; e.g., discharge air sensor, door or window contact input, filter and service alarms, etc.



Check in to comfort. Check out the savings.

Hotel guest comfort meets energy savings
with SE7000 Series room controllers.



Products

Cooling only: Two-pipe fan coil unit with single speed fan and analogue cooling valve	C-2
Cooling with reheat: Two-pipe fan coil unit with three-speed fan, two-position cooling valve and electric reheat	C-4
Cooling only: Two-pipe fan coil unit with single-speed fan, two-position cooling valve and minimum fresh air damper	C-6
Cooling & heating with changeover sensor and reheat: Two-pipe fan coil unit with three-speed fan, analogue valve and electric reheat	C-8
Cooling with reheat: Line voltage, four-pipe fan coil unit with three-speed fan, analogue cooling valve and On/Off heating valve	C-10
Cooling & heating: Four-pipe fan coil unit with single-speed fan, 0-10Vdc analogue cooling and heating valves and external time clock	C-12
Cooling & heating with changeover and reheat: Two-pipe fan coil unit with three-speed fan, tri-state floating valve and electric reheat	C-14
Heating & cooling: Fan coil unit with two-speed fan, DX cooling and two-position heating valve	C-16
Heating & cooling: Four-pipe fan coil unit with three-speed fan, 0-10Vdc analogue valves and dehumidification sequence	C-18
Heating & cooling: Four-pipe fan coil unit with three-speed fan, two-position valves and dehumidification sequence	C-20
Heating & cooling: Four-pipe fan coil unit with three-speed fan, tri-state floating valves and dehumidification sequence	C-22
Heating & cooling: Single-compressor heat pump with two-speed fan and dehumidification sequence	C-24

SE7300F5045

Cooling only: Two-pipe fan coil unit with single speed fan and analogue cooling valve

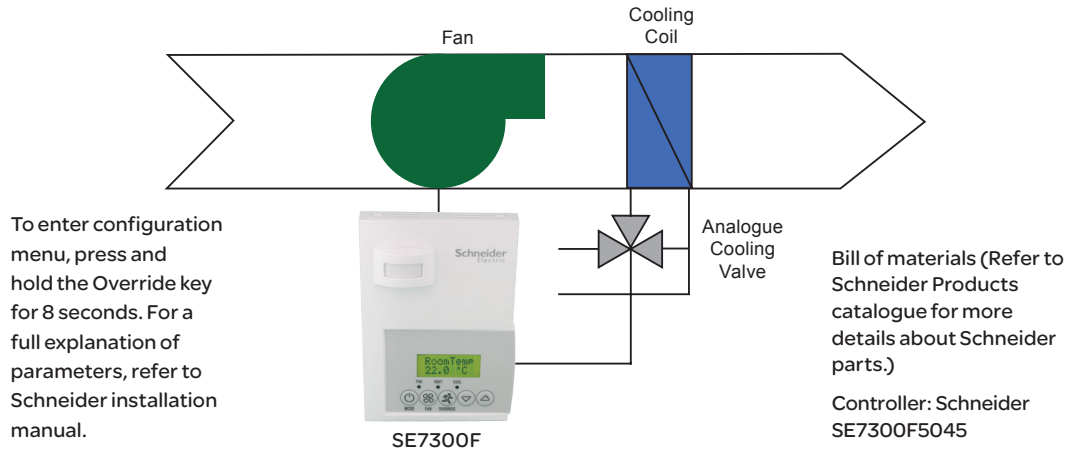

Parameter	Configuration Settings
PswrdSet	0 is factory set, range is: 0-1000
BI1	None
BI2	None
UI3	COS
MenuScro	ON
AutoMode	ON
C or F	As per user. Default value = °F
Lockout	As per user. Default value = 0 No lock
Pipe No	2.0
SeqOpera	0 = Cooling Only
Fan Menu	4
St-By TM	0.5 hours is factory set, range is: 0.0 to 24.0 hours in 0.5hr increments
Unocc TM	0.0 hours is factory set, range is: 0.0 to 24.0 hours in 0.5hr increments
St-By HT	69 °F (20.6 °C) is factory set, range is: 40 to 90 °F (4.5 to 32.0 °C)
St-By CL	78 °F (25.6 °C) is factory set, range is: 54 to 100 °F (12.0 to 37.5 °C)
Unocc HT	As per user. Default value = 62 °F (17 °C). Range = 40 to 90 °F (4.5 to 32.0 °C)
Unocc CL	As per user. Default value = 80 °F (27 °C). Range = 54 to 100 °F (12 to 37.5 °C)
heat max	As per user. Default value = 90 °F (32 °C). Range = 40 to 90 °F (4.5 to 32.0 °C)
cool min	As per user. Default value = 54 °F (12 °C). Range = 54 to 100 °F (12 to 37.5 °C)
Pband	3 °F (1.2 °C) is factory set, range is: 2 to 10 °F (0.6 to 5.6 °C)
Set Type	Permanent
SptFunc	Dual Stp or AttchStp
TOccTime	As per user. Default value 2 hours. Range = 0 to 24 hours
DoorTime	N/A
deadband	As per user. Default value 2.0 °F (1.0 °C). Range = 2, 3, 4 or 5 °F, 1.0 °F increments (1.0 to 2.5 °C, 0.5 °C increments)
cal RS	0 °F or °C
cal RH	0 °F or °C
aux cont	0
Auto Fan	AS or AS AD
cph	N/A
RA/DA	As per Valve
Reheat	0 for ON/OFF (4CPH), 1 for PWM (10 second) only if using SSR
UI3 dis	Displays supply air temperature

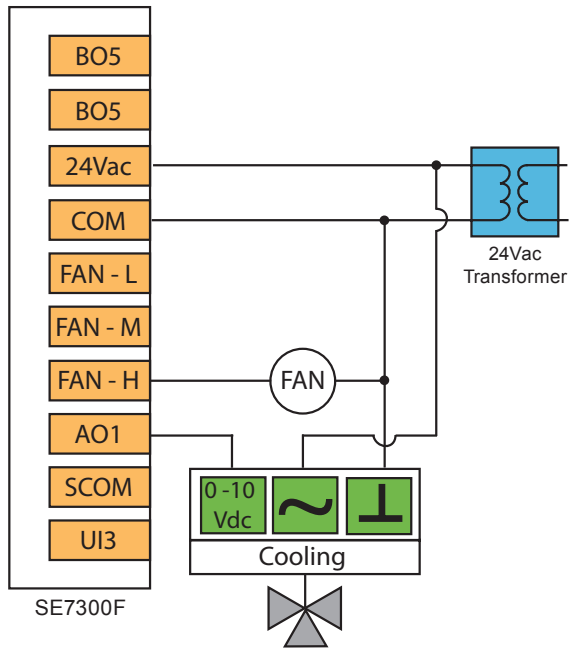

Sequence of Operation and Wiring

Occupied mode:

During occupied periods, the occupied heating and cooling setpoints are used.

PIR activated stand-by and unoccupied modes: When equipped with a PIR (Passive Infrared) accessory cover the controller provides advanced active occupancy logic, which will automatically switch occupancy levels from occupied to stand-by to unoccupied when no motion is detected in the room:

- During PIR activated stand-by periods, the stand-by heating and cooling setpoints are used.
- During PIR activated unoccupied periods, the unoccupied-by heating and cooling setpoints are used.

Unoccupied mode:

During unoccupied periods, the unoccupied heating and cooling setpoints are used.

Local override:

The controller will revert back to the occupied mode as specified by a configuration timer when a local override is requested at the controller.

On a call for cooling:

The cooling valve will modulate from closed to open according to the demand.

Fan mode operation:

The single speed fan can be set to either automatic on demand or always on.

Options

BACnet, Echelon and Wireless models are available. See Appendix B for details.

Remote wall mounted sensor or a return air temperature sensor can be used instead of the internal temperature sensor of the controller.

On-Off control or 3 point floating control operation can be accomplished by using other models.

2 binary inputs and one universal input can be used and configured for advanced functionality as required by the application; e.g., discharge air sensor, door or window contact input, filter and service alarms, etc.

Other fan mode configurations can be set for either single speed, dual speed or three-speed fan mode operation.

SE7300C5045

Cooling with reheat: Two-pipe fan coil unit with three-speed fan, two-position cooling valve and electric reheat

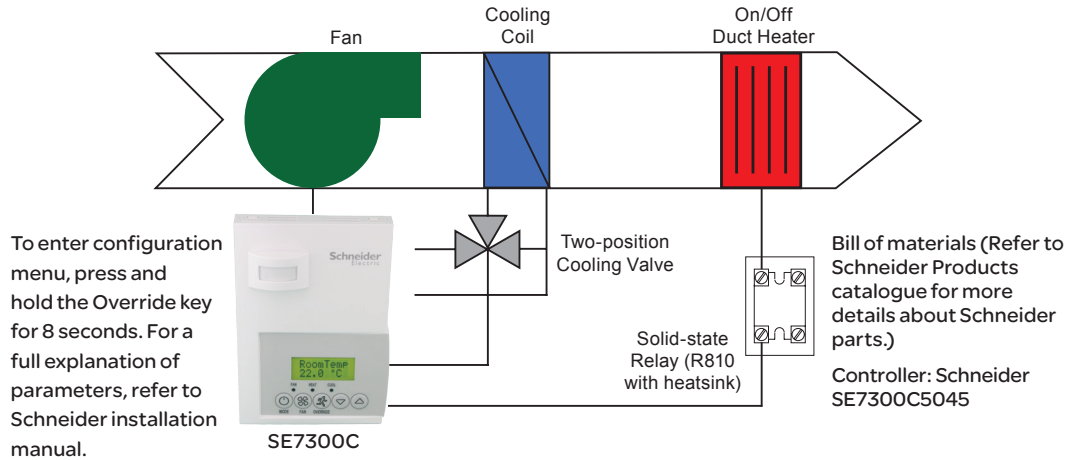

Parameter	Configuration Settings
PswrdSet	0 is factory set, range is: 0-1000
Bl1	None
Bl2	None
UI3	COS
MenuScro	ON
AutoMode	ON
C or F	As per user. Default value = °F
Lockout	As per user. Default value = 0 No lock
Pipe No	2.0
SeqOpera	0 = Cooling Only
Fan Menu	4
St-By TM	0.5 hours is factory set, range is: 0.0 to 24.0 hours in 0.5hr increments
Unocc TM	0.0 hours is factory set, range is: 0.0 to 24.0 hours in 0.5hr increments
St-By HT	69 °F (20.6 °C) is factory set, range is: 40 to 90 °F (4.5 to 32.0 °C)
St-By CL	78 °F (25.6 °C) is factory set, range is: 54 to 100 °F (12.0 to 37.5 °C)
Unocc HT	As per user. Default value = 62 °F (17 °C). Range = 40 to 90 °F (4.5 to 32.0 °C)
Unocc CL	As per user. Default value = 80 °F (27 °C). Range = 54 to 100 °F (12 to 37.5 °C)
heat max	As per user. Default value = 90 °F (32 °C). Range = 40 to 90 °F (4.5 to 32.0 °C)
cool min	As per user. Default value = 54 °F (12 °C). Range = 54 to 100 °F (12 to 37.5 °C)
Pband	3 °F (1.2 °C) is factory set, range is: 2 to 10 °F (0.6 to 5.6 °C)
Set Type	Permanent
SptFunc	Dual Stp or AttchStp
TOccTime	As per user. Default value 2 hours. Range = 0 to 24 hours
DoorTime	N/A
deadband	As per user. Default value 2.0 °F (1.0 °C). Range = 2, 3, 4 or 5 °F, 1.0 °F increments (1.0 to 2.5 °C, 0.5 °C increments)
cal RS	0 °F or °C
cal RH	0 °F or °C
aux cont	0
Auto Fan	AS or AS AD
cph	N/A
RA/DA	As per Valve
Reheat	0 for ON/OFF (4CPH), 1 for PWM (10 second) only if using SSR
UI3 dis	Displays supply air temperature

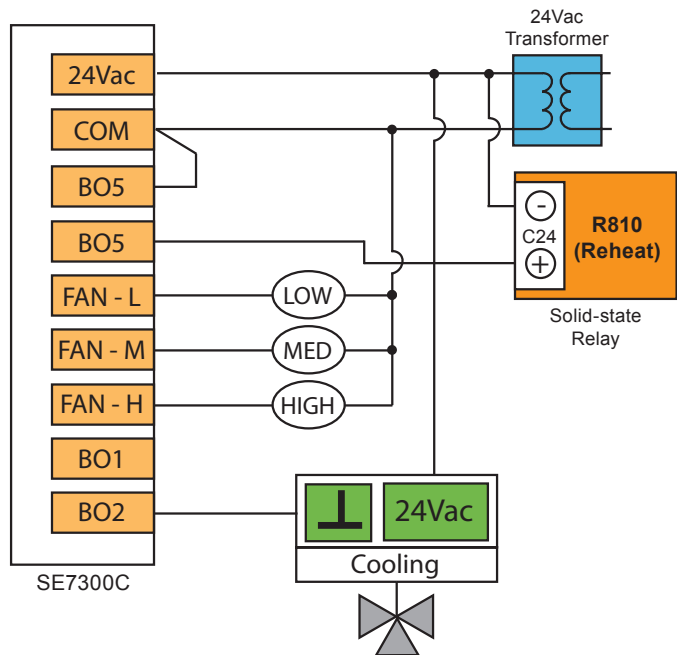

Sequence of Operation and Wiring

Occupied mode:

During occupied periods, the occupied heating and cooling setpoints are used.

PIR activated stand-by and unoccupied modes: When equipped with a PIR (Passive Infrared) accessory cover the controller provides advanced active occupancy logic, which will automatically switch occupancy levels from occupied to stand-by to unoccupied when no motion is detected in the room:

- During PIR activated stand-by periods, the stand-by heating and cooling setpoints are used.
- During PIR activated unoccupied periods, the unoccupied-by heating and cooling setpoints are used.

Unoccupied mode:

During unoccupied periods, the unoccupied heating and cooling setpoints are used.

Local override:

The controller will revert back to the occupied mode as specified by a configuration timer when a local override is requested at the controller.

On a call for cooling:

The cooling valve will open according to the demand.

On a call for heating:

The duct heater will operate according to the demand.

Fan mode operation:

The 3 speed fan can be set to automatic speed on demand, or manually to low, medium or high speed.

Options

BACnet, Echelon and Wireless models are available. See Appendix B for details.

Remote wall mounted sensor or a return air temperature sensor can be used instead of the internal temperature sensor of the controller.

On-Off control or 3 point floating control operation can be accomplished by using other models.

2 binary inputs and one universal input can be used and configured for advanced functionality as required by the application; e.g., discharge air sensor, door or window contact input, filter and service alarms, etc.

Other fan mode configurations can be set for either single speed, dual speed or three-speed fan mode operation.

SE7300C5045

Cooling only: Two-pipe fan coil unit with single-speed fan, two-position cooling valve and minimum fresh air damper

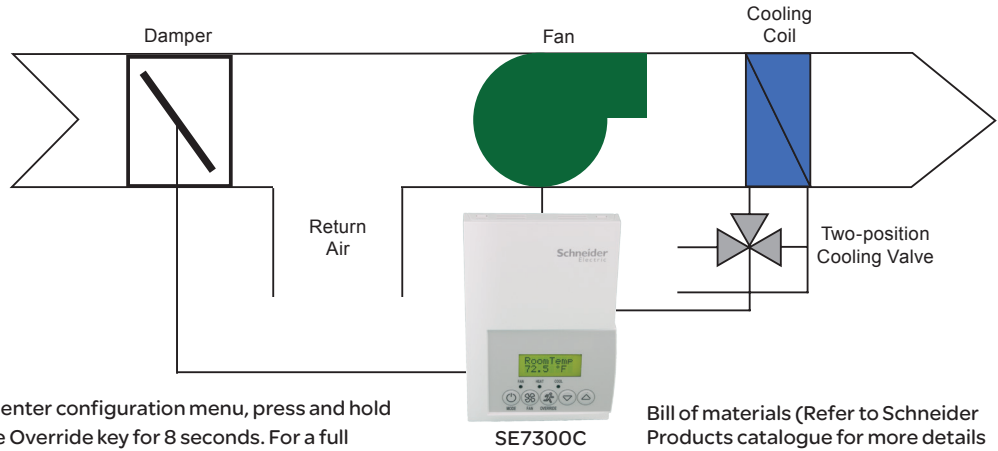

To enter configuration menu, press and hold the Override key for 8 seconds. For a full explanation of parameters, refer to Schneider installation manual.

Bill of materials (Refer to Schneider Products catalogue for more details about Schneider parts.)

Controller: Schneider SE7300C5045

Parameter	Configuration Settings
PswrdSet	0 is factory set, range is: 0-1000
BI1	None
BI2	None
UI3	None
MenuScro	ON
AutoMode	ON
C or F	As per user. Default value = °F
Lockout	As per user. Default value = 0 No lock
Pipe No	2.0
CntrlTyp	On/Off
SeqOpera	0 = Cooling only
Fan Menu	4
St-By TM	0.5 hours is factory set, range is: 0.0 to 24.0 hours in 0.5hr increments
Unocc TM	0.0 hours is factory set, range is: 0.0 to 24.0 hours in 0.5hr increments
St-By HT	69 °F (20.6 °C) is factory set, range is: 40 to 90 °F (4.5 to 32.0 °C)
St-By CL	78 °F (25.6 °C) is factory set, range is: 54 to 100 °F (12.0 to 37.5 °C)
Unocc HT	As per user. Default value = 62 °F (17 °C). Range = 40 to 90 °F (4.5 to 32.0 °C)
Unocc CL	As per user. Default value = 80 °F (27 °C). Range = 54 to 100 °F (12 to 37.5 °C)
heat max	As per user. Default value = 90 °F (32 °C). Range = 40 to 90 °F (4.5 to 32.0 °C)
cool min	As per user. Default value = 54 °F (12 °C). Range = 54 to 100 °F (12 to 37.5 °C)
Pband	3 °F (1.2 °C) is factory set, range is: 2 to 10 °F (0.6 to 5.6 °C)
Set Type	Permanent
SptFunc	Dual Stp or AttchStp
TOccTime	As per user. Default value 2 hours. Range = 0 to 24 hours
DoorTime	N/A
deadband	As per user. Default value 2.0 °F (1.0 °C). Range = 2, 3, 4 or 5 °F, 1.0 °F increments (1.0 to 2.5 °C, 0.5 °C increments)
cal RS	0 °F or °C
cal RH	0 °F or °C
aux cont	1 (occupied=contact closed, unoccupied=contact open)
Auto Fan	AS or AS AD
FL time	As per user. Default value = 1.5 minutes. Range 0.5 to 9.0 in 0.5 minutes increments
cph	N/A
Reheat	Not used

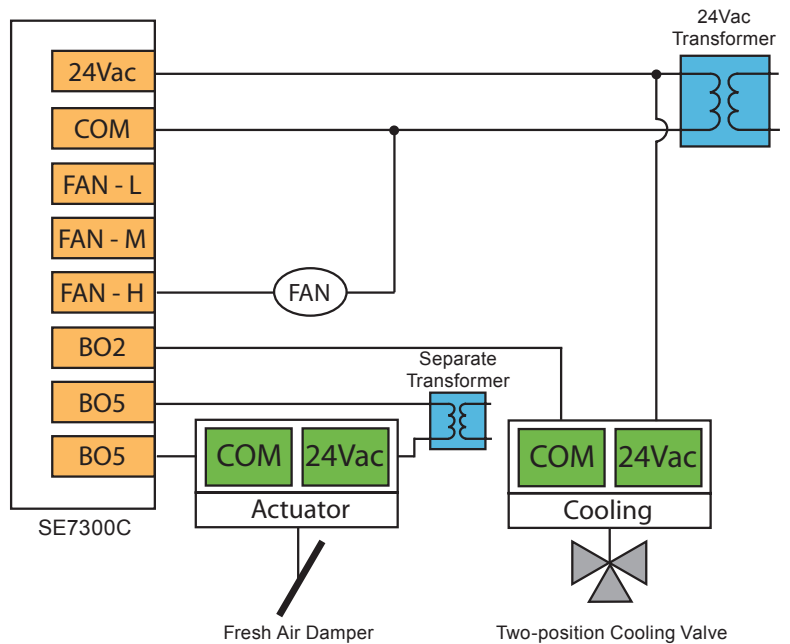

Sequence of Operation and Wiring

Occupied mode:

During occupied periods, the occupied heating and cooling setpoints are used. The auxiliary contact will activate to open the minimum fresh air damper.

PIR activated stand-by and unoccupied modes: When equipped with a PIR (Passive Infrared) accessory cover the controller provides advanced active occupancy logic, which will automatically switch occupancy levels from occupied to stand-by to unoccupied when no motion is detected in the area. The auxiliary contact will activate to open the minimum fresh air damper.

- During PIR activated stand-by periods, the stand-by heating and cooling setpoints are used.
- During PIR activated unoccupied periods, the unoccupied-by heating and cooling setpoints are used.

Unoccupied mode:

During unoccupied periods, the unoccupied heating and cooling setpoints are used. The auxiliary contact will de-activate to close the minimum fresh air damper.

Local override:

The controller will revert back to the occupied mode as specified by a configuration timer when a local override is performed at the controller. The auxiliary contract will activate to open the minimum fresh air damper.

On a call for cooling:

The cooling valve will open according to the demand.

Fan mode operation:

The single speed fan can be set to either automatic on demand or always on.

Options

BACnet, Echelon and Wireless models are available. See Appendix B for details.

Remote wall mounted sensor or a return air temperature sensor can be used instead of the internal temperature sensor of the controller.

On-Off control or 3 point floating control operation can be accomplished by using other models.

2 binary inputs and one universal input can be used and configured for advanced functionality as required by the application; e.g., discharge air sensor, door or window contact input, filter and service alarms, etc.

Other fan mode configurations can be set for either single speed, dual speed or three-speed fan mode operation.

SE7300F5045

Cooling & heating with changeover sensor and reheat: Two-pipe fan coil unit with three-speed fan, analogue valve and electric reheat

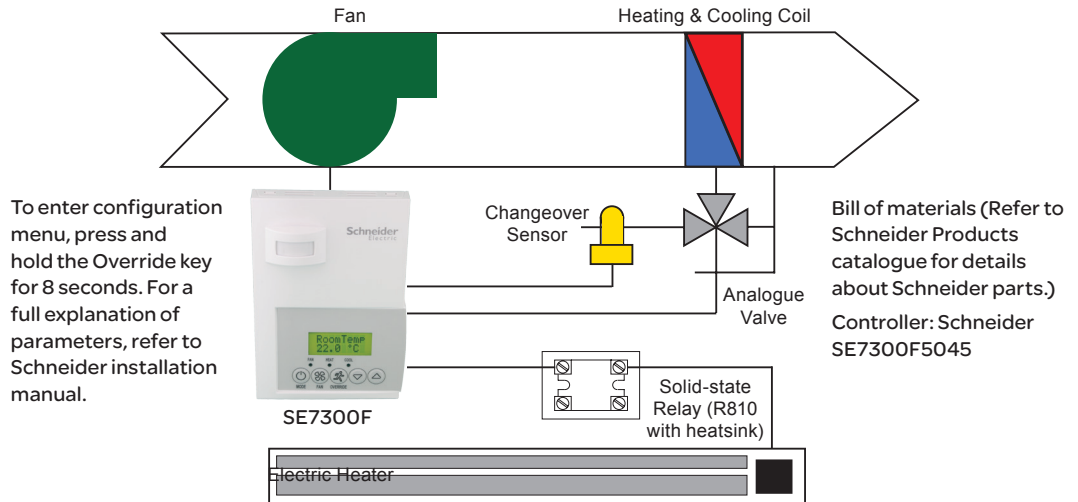

Parameter	Configuration Settings
PswrdSet	0 is factory set, range is: 0-1000
BI1	None
BI2	None
UI3	COS
MenuScro	ON
AutoMode	ON
C or F	As per user. Default value = °F
Lockout	As per user. Default value = 0 No lock
Pipe No	2.0
SeqOpera	2 = Cooling with Reheat
Fan Menu	2
St-By TM	0.5 hours is factory set, range is: 0.0 to 24.0 hours in 0.5hr increments
Unocc TM	0.0 hours is factory set, range is: 0.0 to 24.0 hours in 0.5hr increments
St-By HT	69 °F (20.6 °C) is factory set, range is: 40 to 90 °F (4.5 to 32.0 °C)
St-By CL	78 °F (25.6 °C) is factory set, range is: 54 to 100 °F (12.0 to 37.5 °C)
Unocc HT	As per user. Default value = 62 °F (17 °C). Range = 40 to 90 °F (4.5 to 32.0 °C)
Unocc CL	As per user. Default value = 80 °F (27 °C). Range = 54 to 100 °F (12 to 37.5 °C)
heat max	As per user. Default value = 90 °F (32 °C). Range = 40 to 90 °F (4.5 to 32.0 °C)
cool min	As per user. Default value = 54 °F (12 °C). Range = 54 to 100 °F (12 to 37.5 °C)
Pband	3 °F (1.2 °C) is factory set, range is: 2 to 10 °F (0.6 to 5.6 °C)
Set Type	Permanent
SptFunc	Dual Stp or AttchStp
TOccTime	As per user. Default value 2 hours. Range = 0 to 24 hours
DoorTime	N/A
deadband	As per user. Default value 2.0 °F (1.0 °C). Range = 2, 3, 4 or 5 °F, 1.0 °F increments (1.0 to 2.5 °C, 0.5 °C increments)
cal RS	0 °F or °C
cal RH	0 °F or °C
aux cont	0
Auto Fan	AS or AS AD
RA/DA	As per Valve
Reheat	0 for ON/OFF (4CPH), 1 for PWM (10 second) only if using SSR
UI3 dis	Displays supply air temperature

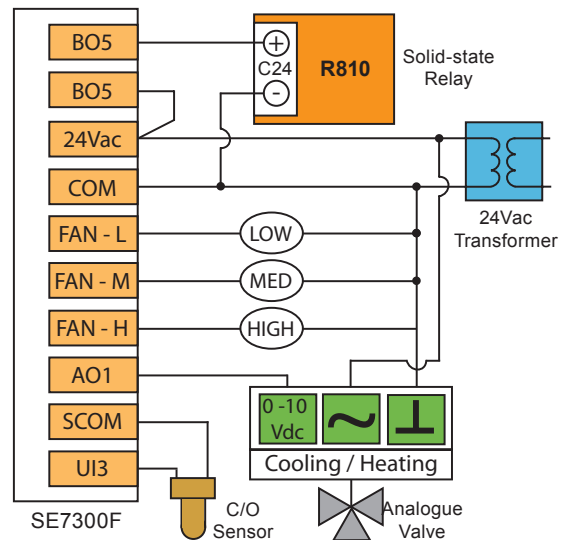

Sequence of Operation and Wiring

Occupied mode:

During occupied periods, the occupied heating and cooling setpoints are used.

PIR activated stand-by and unoccupied modes: When equipped with a PIR (Passive Infrared) accessory cover the controller provides advanced active occupancy logic, which will automatically switch occupancy levels from occupied to stand-by to unoccupied when no motion is detected in the area.

- During PIR activated stand-by periods, the stand-by heating and cooling setpoints are used.
- During PIR activated unoccupied periods, the unoccupied-by heating and cooling setpoints are used.

Unoccupied mode:

During unoccupied periods, the unoccupied heating and cooling setpoints are used.

Local override:

The controller will revert back to the occupied mode as specified by a configuration timer when a local override is performed at the controller.

On a call for cooling:

If the supply water temperature is less than 75°F (23.9°C), the valve will modulate from closed to open according to demand. If the water supply temperature is greater than 77°F, the valve will remain closed.

On a call for heating:

If the supply water temperature is greater than 77°F (25°C), the valve will modulate from closed to open according to demand. If the water supply temperature is less than 75°F (23.9°C), the valve will remain closed. The perimeter heater will operate as a second step.

Fan mode operation:

The 3 speed fan can be set to automatic speed on demand, or manually to low, medium or high speed.

Options

BACnet, Echelon and Wireless models are available. See Appendix B for details.

Remote wall mounted sensor or a return air temperature sensor can be used instead of the internal temperature sensor of the controller.

On-Off control or 3 point floating control operation can be accomplished by using other models.

2 binary inputs and one universal input can be used and configured for advanced functionality as required by the application; e.g., discharge air sensor, door or window contact input, filter and service alarms, etc.

Other fan mode configurations can be set for either single speed, dual speed or three-speed fan mode operation.

SE7300F5045

Cooling with reheat: Line voltage, four-pipe fan coil unit with three-speed fan, analogue cooling valve and on/off heating valve

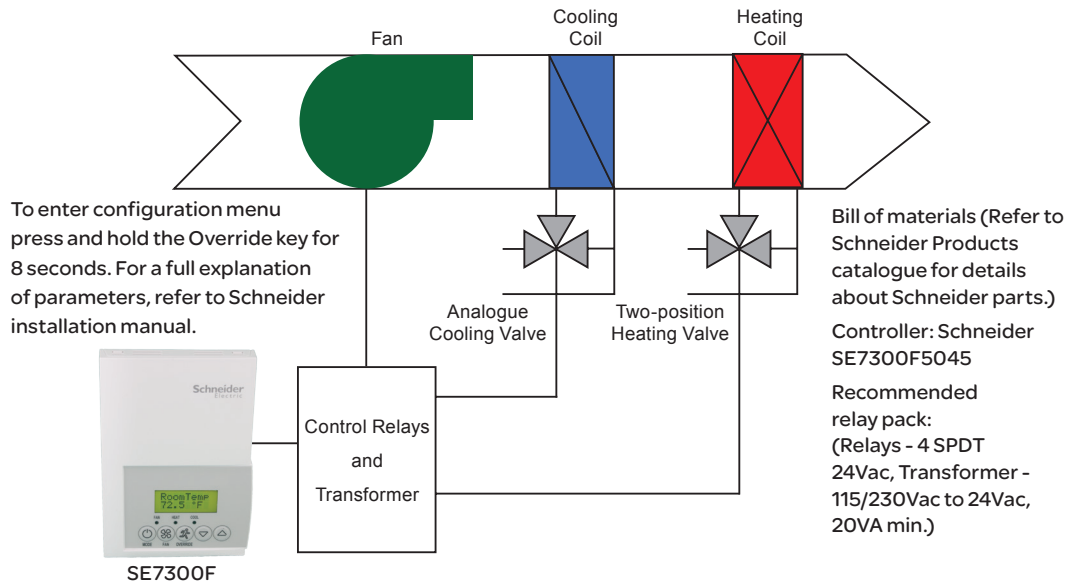

Parameter	Configuration Settings
PswrdSet	0 is factory set, range is: 0-1000
BI1	None
BI2	None
UI3	None
MenuScro	ON
AutoMode	ON
C or F	As per user. Default value = °F
Lockout	As per user. Default value = 0 No lock
Pipe No	4.0
SeqOpera	2 = Cooling with Reheat
Fan Menu	2
St-By TM	0.5 hours is factory set, range is: 0.0 to 24.0 hours in 0.5hr increments
Unocc TM	0.0 hours is factory set, range is: 0.0 to 24.0 hours in 0.5hr increments
St-By HT	69 °F (20.6 °C) is factory set, range is: 40 to 90 °F (4.5 to 32.0 °C)
St-By CL	78 °F (25.6 °C) is factory set, range is: 54 to 100 °F (12.0 to 37.5 °C)
Unocc HT	As per user. Default value = 62 °F (17 °C). Range = 40 to 90 °F (4.5 to 32.0 °C)
Unocc CL	As per user. Default value = 80 °F (27 °C). Range = 54 to 100 °F (12 to 37.5 °C)
heat max	As per user. Default value = 90 °F (32 °C). Range = 40 to 90 °F (4.5 to 32.0 °C)
cool min	As per user. Default value = 54 °F (12 °C). Range = 54 to 100 °F (12 to 37.5 °C)
Pband	3 °F (1.2 °C) is factory set, range is: 2 to 10 °F (0.6 to 5.6 °C)
Set Type	Permanent
SptFunc	Dual Stp or AttchStp
TOccTime	As per user. Default value 2 hours. Range = 0 to 24 hours
DoorTime	N/A
deadband	As per user. Default value 2.0 °F (1.0 °C). Range = 2, 3, 4 or 5 °F, 1.0 °F increments (1.0 to 2.5 °C, 0.5 °C increments)
cal RS	0 °F or °C
cal RH	0 °F or °C
aux cont	0
Auto Fan	AS or AS AD
RA/DA	As per Valve
Reheat	0 for oN/oFF (4CPH), 1 for PWM (10 second) only if using SSR
UI3 dis	Displays supply air temperature

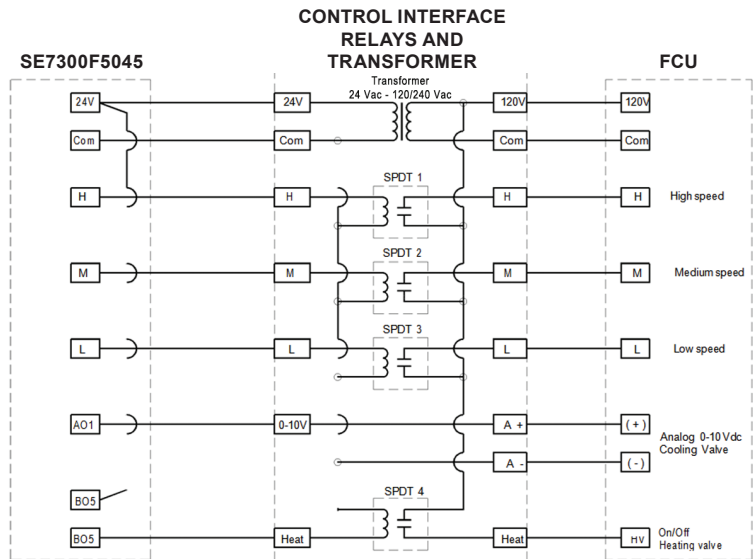

Sequence of Operation and Wiring

Occupied mode:

During occupied periods, the occupied heating and cooling setpoints are used.

PIR activated stand-by and unoccupied modes: When equipped with a PIR (Passive Infrared) accessory cover the controller provides advanced active occupancy logic, which will automatically switch occupancy levels from occupied to stand-by to unoccupied when no motion is detected in the room.

- During PIR activated stand-by periods, the stand-by heating and cooling setpoints are used.
- During PIR activated unoccupied periods, the unoccupied-by heating and cooling setpoints are used.

Unoccupied mode:

During unoccupied periods, the unoccupied heating and cooling setpoints are used.

Local override:

The controller will revert back to the occupied mode as specified by a configuration timer when a local override is requested at the controller.

On a call for cooling:

The cooling valve will modulate from closed to open according to the demand.

On a call for heating:

The heating valve will open according to demand.

Fan mode operation:

The 3 speed fan can be set to automatic speed on demand, or manually to low, medium or high speed.

Options

BACnet, Echelon and Wireless models are available. See Appendix B for details.

Remote wall mounted sensor or a return air temperature sensor can be used instead of the internal temperature sensor of the controller.

On-Off control or 3 point floating control operation can be accomplished by using other models.

2 binary inputs and one universal input can be used and configured for advanced functionality as required by the application; e.g., discharge air sensor, door or window contact input, filter and service alarms, etc.

Other fan mode configurations can be set for either single speed, dual speed or three-speed fan mode operation.

SE7300F5045

Cooling & heating: Four-pipe fan coil unit with single-speed fan, 0-10Vdc analogue cooling and heating valves and external time clock

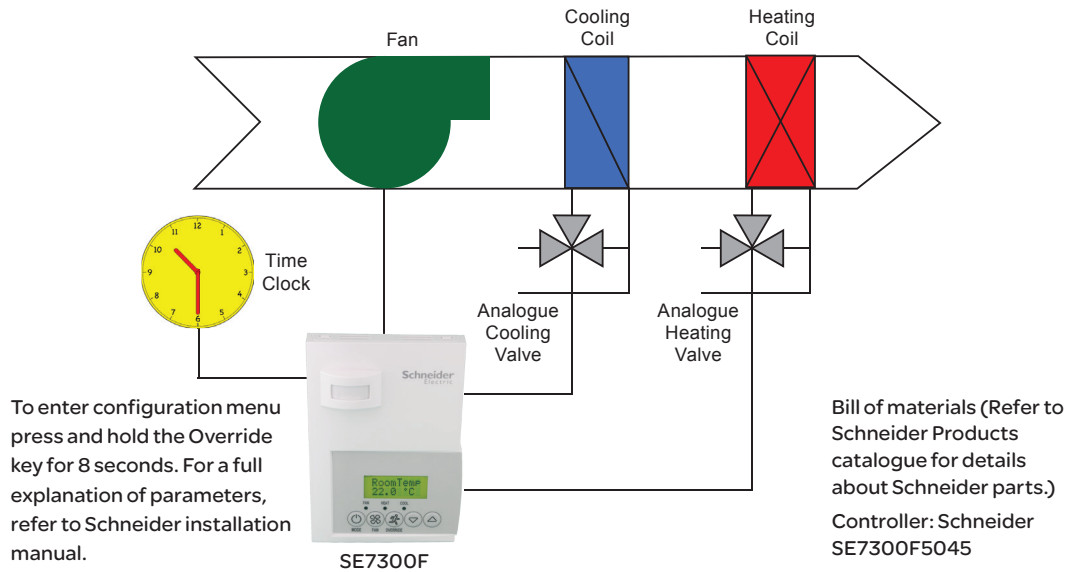

Parameter	Configuration Settings
PswrdSet	0 is factory set, range is: 0-1000
BI1	Rem NSB
BI2	None
UI3	None
MenuScro	ON
AutoMode	ON
C or F	As per user. Default value = °F
Lockout	As per user. Default value = 0 No lock
Pipe No	4.0
SeqOpera	4 = Cooling and heating
Fan Menu	4 = On-Auto
St-By TM	0.5 hours is factory set, range is: 0.0 to 24.0 hours in 0.5hr increments
Unocc TM	0.0 hours is factory set, range is: 0.0 to 24.0 hours in 0.5hr increments
St-By HT	69 °F (20.6 °C) is factory set, range is: 40 to 90 °F (4.5 to 32.0 °C)
St-By CL	78 °F (25.6 °C) is factory set, range is: 54 to 100 °F (12.0 to 37.5 °C)
Unocc HT	As per user. Default value = 62 °F (17 °C). Range = 40 to 90 °F (4.5 to 32.0 °C)
Unocc CL	As per user. Default value = 80 °F (27 °C). Range = 54 to 100 °F (12 to 37.5 °C)
heat max	As per user. Default value = 90 °F (32 °C). Range = 40 to 90 °F (4.5 to 32.0 °C)
cool min	As per user. Default value = 54 °F (12 °C). Range = 54 to 100 °F (12 to 37.5 °C)
Pband	3 °F (1.2 °C) is factory set, range is: 2 to 10 °F (0.6 to 5.6 °C)
Set Type	Permanent
SptFunc	Dual Stp or AttchStp
TOccTime	As per user. Default value 2 hours. Range = 0 to 24 hours
DoorTime	N/A
deadband	As per user. Default value 2.0 °F (1.0 °C). Range = 2, 3, 4 or 5 °F, 1.0 °F increments (1.0 to 2.5 °C, 0.5 °C increments)
cal RS	0 °F or °C
cal RH	0 °F or °C
aux cont	0
Auto Fan	AS or AS AD
RA/DA	As per Valve
Reheat	0 for ON/OFF (4CPH), 1 for PWM (10 second) only if using SSR
UI3 dis	Displays supply air temperature

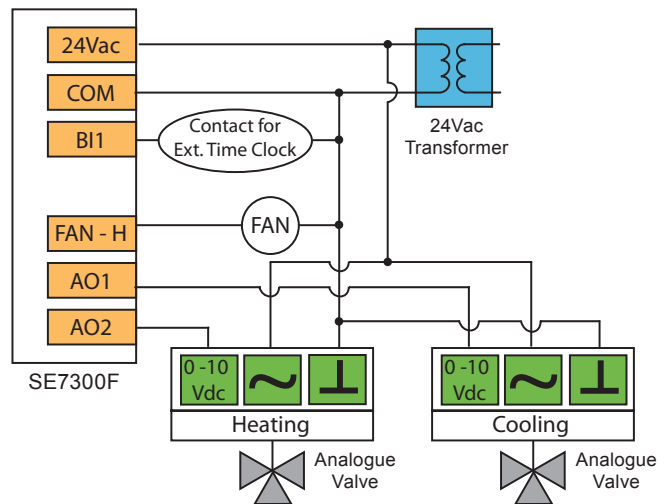

Sequence of Operation and Wiring

Occupancy command from an external time clock:

The occupancy is controlled by an external 24 Vac time clock:

- When the contact of the time clock closes on binary input #1 (BI1), the controller will be in occupied mode.
- When the contact of the time clock opens on binary input #1 (BI1), the controller will be in unoccupied mode.

Occupied mode:

During occupied periods, the occupied heating and cooling setpoints are used.

PIR activated stand-by and unoccupied modes: When equipped with a PIR (Passive Infrared) accessory cover the controller provides advanced active occupancy logic, which will automatically switch occupancy levels from occupied to stand-by to unoccupied when no motion is detected in the room.

- During PIR activated stand-by periods, the stand-by heating and cooling setpoints are used.
- During PIR activated unoccupied periods, the unoccupied-by heating and cooling setpoints are used.

Unoccupied mode:

During unoccupied periods, the unoccupied heating and cooling setpoints are used.

Local override:

The controller will revert back to the occupied mode as specified by a configuration timer when a local override is requested at the controller.

On a call for cooling:

The cooling valve will modulate from closed to open according to the demand.

On a call for heating:

The heating valve will modulate from closed to open according to the demand.

Fan mode operation:

The single speed fan can be set to either automatic on demand or always on.

Options

BACnet, Echelon and Wireless models are available. See Appendix B for details.

Remote wall mounted sensor or a return air temperature sensor can be used instead of the internal temperature sensor of the controller.

On-Off control or 3 point floating control operation can be accomplished by using other models.

2 binary inputs and one universal input can be used and configured for advanced functionality as required by the application; e.g., discharge air sensor, door or window contact input, filter and service alarms, etc.

Other fan mode configurations can be set for either single speed, dual speed or three-speed fan mode operation.

SE7300C5045

Cooling & heating with changeover and reheat:
Two-pipe fan coil unit with three-speed fan,
tri-state floating valve and electric reheat

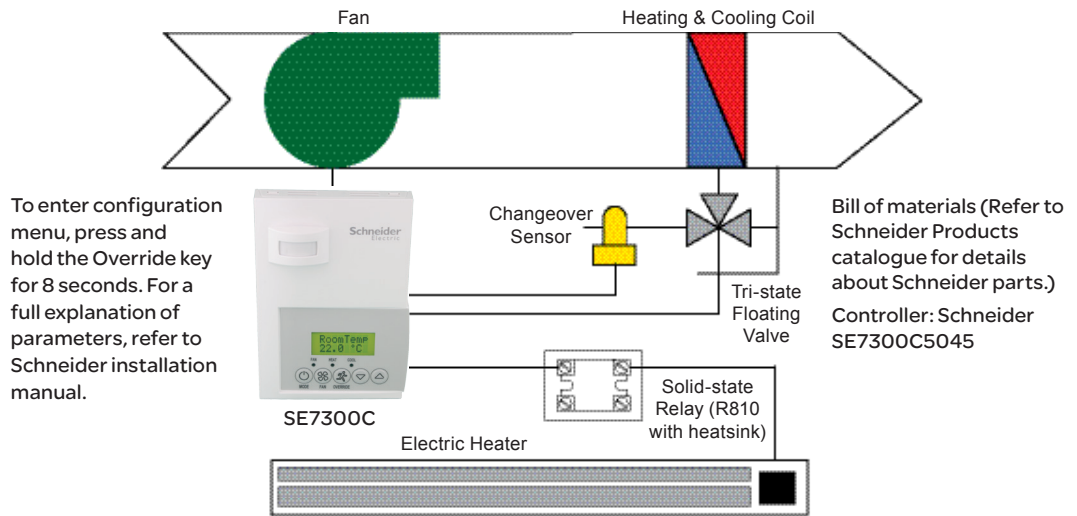

Parameter	Configuration Settings
PswrdSet	0 is factory set, range is: 0-1000
BI1	None
BI2	None
UI3	COS
MenuScro	ON
AutoMode	ON
C or F	As per user. Default value = °F
Lockout	As per user. Default value = 0 No lock
Pipe No	2.0
CntrlTyp	Floating
SeqOpera	2 = Cooling with Reheat
Fan Menu	2
St-By TM	0.5 hours is factory set, range is: 0.0 to 24.0 hours in 0.5hr increments
Unocc TM	0.0 hours is factory set, range is: 0.0 to 24.0 hours in 0.5hr increments
St-By HT	69 °F (20.6 °C) is factory set, range is: 40 to 90 °F (4.5 to 32.0 °C)
St-By CL	78 °F (25.6 °C) is factory set, range is: 54 to 100 °F (12.0 to 37.5 °C)
Unocc HT	As per user. Default value = 62 °F (17 °C). Range = 40 to 90 °F (4.5 to 32.0 °C)
Unocc CL	As per user. Default value = 80 °F (27 °C). Range = 54 to 100 °F (12 to 37.5 °C)
heat max	As per user. Default value = 90 °F (32 °C). Range = 40 to 90 °F (4.5 to 32.0 °C)
cool min	As per user. Default value = 54 °F (12 °C). Range = 54 to 100 °F (12 to 37.5 °C)
Pband	3 °F (1.2 °C) is factory set, range is: 2 to 10 °F (0.6 to 5.6 °C)
Set Type	Permanent
SptFunc	Dual Stp or AttchStp
TOccTime	As per user. Default value 2 hours. Range = 0 to 24 hours
DoorTime	N/A
deadband	As per user. Default value 2.0 °F (1.0 °C). Range = 2, 3, 4 or 5 °F, 1.0 °F increments (1.0 to 2.5 °C, 0.5 °C increments)
cal RS	0 °F or °C
cal RH	0 °F or °C
aux cont	0
Auto Fan	AS or AS AD
FL time	As per user. Default value = 1.5 minutes. Range 0.5 to 9.0 in 0.5 minutes increments
cph	N/A
Reheat	0 for ON/OFF (4CPH), 1 for PWM (10 second)
UI3 dis	Displays supply air temperature

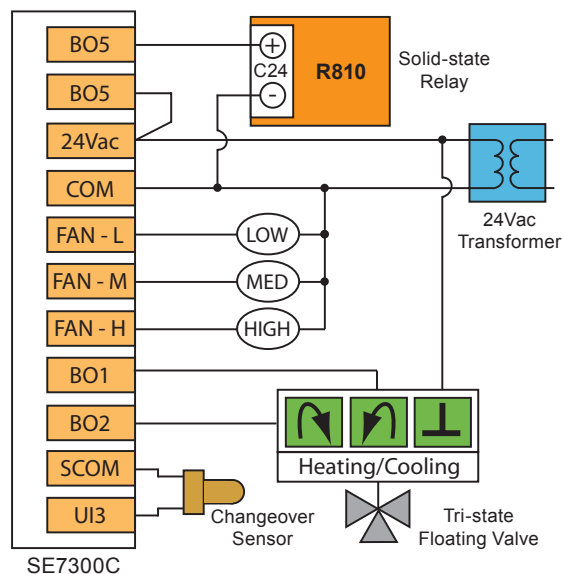

Sequence of Operation and Wiring

Occupied mode:

During occupied periods, the occupied heating and cooling setpoints are used.

PIR activated stand-by and unoccupied modes: When equipped with a PIR (Passive Infrared) accessory cover the controller provides advanced active occupancy logic, which will automatically switch occupancy levels from occupied to stand-by to unoccupied when no motion is detected in the room.

- During PIR activated stand-by periods, the stand-by heating and cooling setpoints are used.
- During PIR activated unoccupied periods, the unoccupied-by heating and cooling setpoints are used.

Unoccupied mode:

During unoccupied periods, the unoccupied heating and cooling setpoints are used.

Local override:

The controller will revert back to the occupied mode as specified by a configuration timer when a local override is requested at the controller.

On a call for cooling:

If the supply water temperature is less than 75°F (23.9°C), the valve modulates from closed to open according to demand. If the water supply temperature is greater than 77°F (25°C), the valve remains closed.

On a call for heating:

If the supply water temperature is greater than 77°F (25°C), the valve modulates from closed to open according to demand. If the water supply temperature is less than 75°F (23.9°C), the valve remains closed. The perimeter heater operates as a second step.

Fan mode operation:

The 3 speed fan can be set to automatic speed on demand, or manually to low, medium or high speed.

Options

BACnet, Echelon and Wireless models are available. See Appendix B for details.

Remote wall mounted sensor or a return air temperature sensor can be used instead of the internal temperature sensor of the controller.

On-Off control or 3 point floating control operation can be accomplished by using other models.

2 binary inputs and one universal input can be used and configured for advanced functionality as required by the application; e.g., discharge air sensor, door or window contact input, filter and service alarms, etc.

Other fan mode configurations can be set for either single speed, dual speed or three-speed fan mode operation.

SE7300C5045

Heating & cooling: Fan coil unit with two-speed fan, DX cooling and two-position heating valve - wireless network

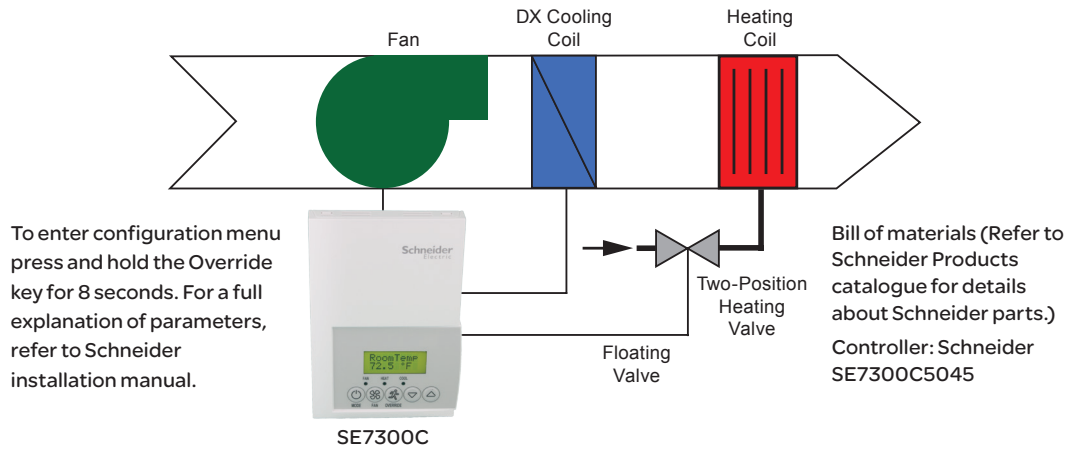

Parameter	Configuration Settings
PswrdSet	0 is factory set, range is: 0-1000
BI1	None
BI2	None
UI3	None
MenuScro	ON
AutoMode	ON
C or F	As per user. Default value = °F
Lockout	As per user. Default value = 0 No lock
Pipe No	4.0
SeqOpera	4 = Cooling / Heating 4 pipes
Fan Menu	1 = Low-High
St-By TM	0.5 hours is factory set, range is: 0.0 to 24.0 hours in 0.5hr increments
Unocc TM	0.0 hours is factory set, range is: 0.0 to 24.0 hours in 0.5hr increments
St-By HT	69 °F (20.6 °C) is factory set, range is: 40 to 90 °F (4.5 to 32.0 °C)
St-By CL	78 °F (25.6 °C) is factory set, range is: 54 to 100 °F (12.0 to 37.5 °C)
Unocc HT	As per user. Default value = 62 °F (17 °C). Range = 40 to 90 °F (4.5 to 32.0 °C)
Unocc CL	As per user. Default value = 80 °F (27 °C). Range = 54 to 100 °F (12 to 37.5 °C)
heat max	As per user. Default value = 90 °F (32 °C). Range = 40 to 90 °F (4.5 to 32.0 °C)
cool min	As per user. Default value = 54 °F (12 °C). Range = 54 to 100 °F (12 to 37.5 °C)
Pband	3 °F (1.2 °C) is factory set, range is: 2 to 10 °F (0.6 to 5.6 °C)
Set Type	Permanent
SptFunc	Dual Stp or AttchStp
TOccTime	As per user. Default value 2 hours. Range = 0 to 24 hours
DoorTime	N/A
deadband	As per user. Default value 2.0 °F (1.0 °C). Range = 2, 3, 4 or 5 °F, 1.0 °F increments 1.0 to 2.5 °C, 0.5 °C increments)
cal RS	0 °F or °C
aux cont	0
Auto Fan	AS or AS AD
FL time	As per user. Default value = 1.5 minutes. Range 0.5 to 9.0 in 0.5 minutes increments
cph	N/A
Reheat	0 for ON/OFF (4CPH), 1 for PWM (10 second)
UI3 dis	Displays supply air temperature

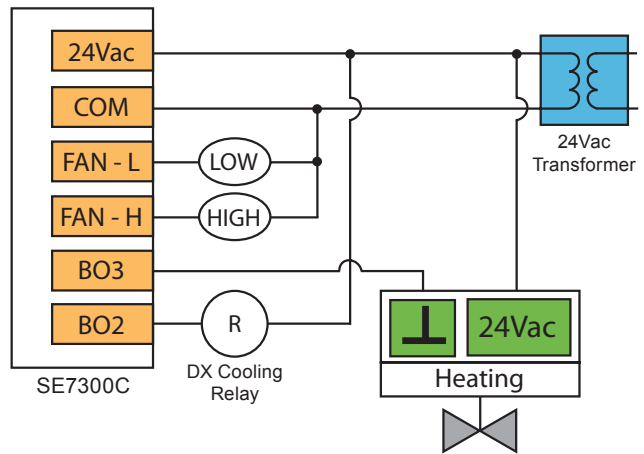

Sequence of Operation and Wiring

Occupied mode:

During occupied periods, the occupied heating and cooling setpoints are used. The auxiliary contact will activate to open the minimum fresh air damper.

PIR activated stand-by and unoccupied modes: When equipped with a PIR (Passive Infrared) accessory cover the controller provides advanced active occupancy logic, which will automatically switch occupancy levels from occupied to stand-by to unoccupied when no motion is detected in the area. The auxiliary contact will activate to open the minimum fresh air damper.

- During PIR activated stand-by periods, the stand-by heating and cooling setpoints are used.
- During PIR activated unoccupied periods, the unoccupied-by heating and cooling setpoints are used.

Unoccupied mode:

During unoccupied periods, the unoccupied heating and cooling setpoints are used. The auxiliary contact will de-activate to close the minimum fresh air damper.

Local override:

The controller will revert back to the occupied mode as specified by a configuration timer when a local override is performed at the controller. The auxiliary contact will activate to open the minimum fresh air damper.

On a call for cooling:

The cooling relay will operate the DX cooling stage according to demand.

On a call for heating:

The heating valve will open according to demand.

Fan mode operation:

The two-speed fan can be set either to automatic speed on demand or manually to either low or medium speed.

Options

BACnet, Echelon and Wireless models are available. See Appendix B for details.

On-Off control or 3 point floating control operation can be accomplished by using other models.

2 binary inputs and one universal input can be used and configured for advanced functionality as required by the application; e.g., discharge air sensor, door or window contact input, filter and service alarms, etc.

Other fan mode configurations can be set for either single speed, dual speed or three-speed fan mode operation.

SE7355F5045

Heating & cooling: Four-pipe fan coil unit with three-speed fan, 0-10Vdc analogue valves and dehumidification sequence

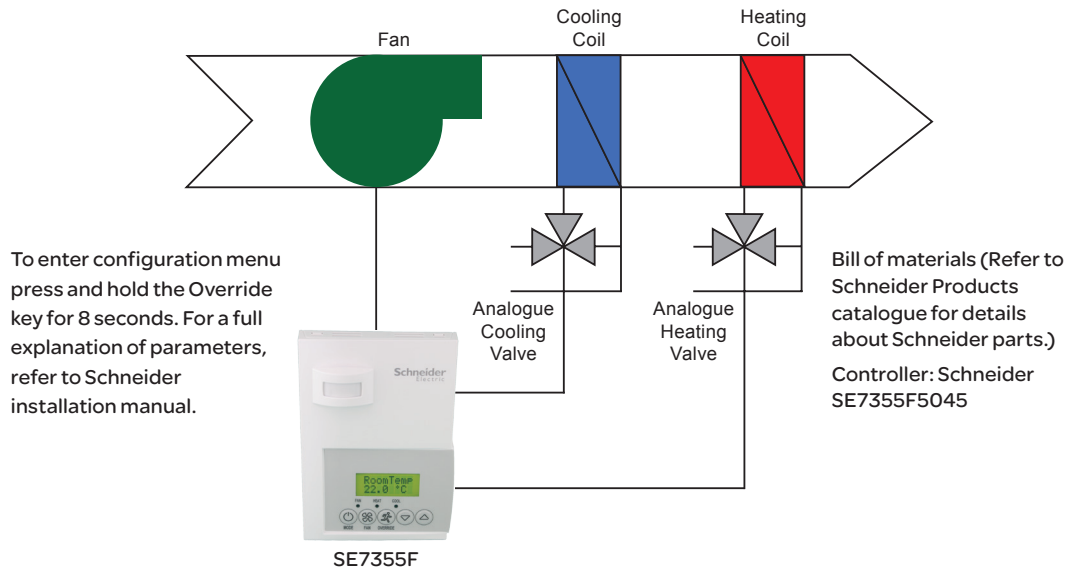

Parameter	Configuration Settings
PswrdSet	0 is factory set, range is: 0-1000
BI1	None
BI2	None
UI3	None
MenuScro	ON
AutoMode	ON
C or F	As per user. Default value = °F
%RH disp	ON
Lockout	As per user. Default value = 0 No lock
Pipe No	4.0
SeqOpera	4 = Cooling / Heating 4 pipes
Fan Menu	2
DHumiLCK	ON
%RH set	As per user. Default value = 50%. Range = 30% to 95%
DehuHyst	As per user. Default value = 5%. Range = 2% to 20%
DehuCool	As per user. Default value = 100%. Range = 20% to 100%
St-By TM	0.5 hours is factory set, range is: 0.0 to 24.0 hours in 0.5hr increments
Unocc TM	0.0 hours is factory set, range is: 0.0 to 24.0 hours in 0.5hr increments
St-By HT	69 °F (20.6 °C) is factory set, range is: 40 to 90 °F (4.5 to 32.0 °C)
St-By CL	78 °F (25.6 °C) is factory set, range is: 54 to 100 °F (12.0 to 37.5 °C)
Unocc HT	As per user. Default value = 62 °F (17 °C). Range = 40 to 90 °F (4.5 to 32.0 °C)
Unocc CL	As per user. Default value = 80 °F (27 °C). Range = 54 to 100 °F (12 to 37.5 °C)
heat max	As per user. Default value = 90 °F (32 °C). Range = 40 to 90 °F (4.5 to 32.0 °C)
cool min	As per user. Default value = 54 °F (12 °C). Range = 54 to 100 °F (12 to 37.5 °C)
Pband	3 °F (1.2 °C) is factory set, range is: 2 to 10 °F (0.6 to 5.6 °C)
Set Type	Permanent
SptFunc	Dual Stp or AttchStp
TOccTime	As per user. Default value 2 hours. Range = 0 to 24 hours
DoorTime	N/A
deadband	As per user. Default value 2.0 °F (1.0 °C). Range = 2, 3, 4 or 5 °F, 1.0 °F increments (1.0 to 2.5 °C, 0.5 °C increments)
cal RS	0 °F or °C
cal RH	0 °F or °C
aux cont	0
Auto Fan	AS or AS AD
RA/DA	Reverse Acting (RA) or Direct Acting (DA), depends on actuator
Reheat	0 for ON/OFF (4CPH), 1 for PWM (10 second)
UI3 dis	Displays supply air temperature

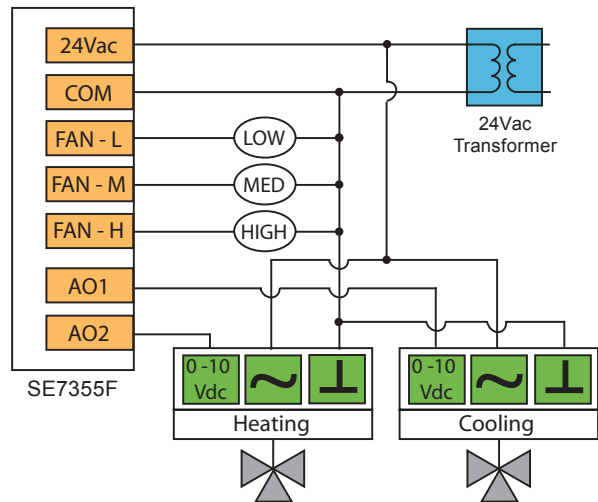

Sequence of Operation and Wiring

Occupied mode:

During occupied periods, the occupied heating and cooling setpoints are used.

PIR activated stand-by and unoccupied modes: When equipped with a PIR (Passive Infrared) accessory cover the controller provides advanced active occupancy logic, which will automatically switch occupancy levels from occupied to stand-by to unoccupied when no motion is detected in the room.

- During PIR activated stand-by periods, the stand-by heating and cooling setpoints are used.
- During PIR activated unoccupied periods, the unoccupied-by heating and cooling setpoints are used.

Unoccupied mode:

During unoccupied periods, the unoccupied heating & cooling setpoints are used.

Local override:

The controller will revert back to the occupied mode as specified by a configuration timer when a local override is performed at the controller.

On a call for cooling:

The cooling valve will open according to demand. Dehumidification is authorized during cooling operation.

On a call for heating:

The heating valve will modulate from closed to open according to demand. Dehumidification is not authorized during heating operation.

Fan mode operation:

The two-speed fan can be set either to automatic speed on demand or manually to either low or medium speed.

On a demand for dehumidification:

Dehumidification is achieved via the cooling coil using the heating coil for reheat if necessary. Dehumidification is only allowed in COOL mode (or if cooling is enabled in AUTO mode). Dehumidification is disabled if the room temperature falls below the room low ambient dehumidification temperature.

Options

BACnet, Echelon and Wireless models are available. See appendix B for details.

Remote wall mounted sensor or a return air temperature sensor can be used instead of the internal temperature sensor of the controller.

On-Off control or 3 point floating control operation can be accomplished by using other models.

2 binary inputs and one universal input can be used and configured for advanced functionality as required by the application; e.g., discharge air sensor, door or window contact input, filter and service alarms, etc.

Other fan mode configurations can be set for either single speed, dual speed or three-speed fan mode operation.

SE7355C5045

Heating & cooling: Four-pipe fan coil unit with three-speed fan, two-position valves and dehumidification sequence

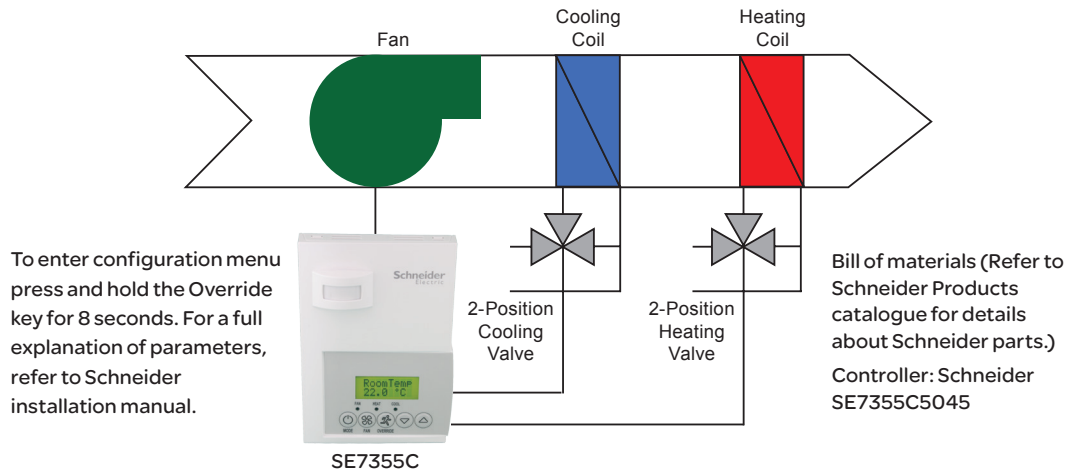

Parameter	Configuration Settings
PswrdSet	0 is factory set, range is: 0-1000
BI1	None
BI2	None
UI3	None
MenuScro	ON
AutoMode	ON
C or F	As per user. Default value = °F
%RH disp	ON
Lockout	As per user. Default value = 0 No lock
Pipe No	4.0
CntrlTyp	On/Off
SeqOpera	4 = Cooling / Heating 4 pipes
Fan Menu	2
DHumiLCK	ON
%RH set	As per user. Default value = 50%. Range = 30% to 95%
DehuHyst	As per user. Default value = 5%. Range = 2% to 20%
DehuCool	As per user. Default value = 100%. Range = 20% to 100%
St-By TM	0.5 hours is factory set, range is: 0.0 to 24.0 hours in 0.5hr increments
Unocc TM	0.0 hours is factory set, range is: 0.0 to 24.0 hours in 0.5hr increments
St-By HT	69 °F (20.6 °C) is factory set, range is: 40 to 90 °F (4.5 to 32.0 °C)
St-By CL	78 °F (25.6 °C) is factory set, range is: 54 to 100 °F (12.0 to 37.5 °C)
Unocc HT	As per user. Default value = 62 °F (17 °C). Range = 40 to 90 °F (4.5 to 32.0 °C)
Unocc CL	As per user. Default value = 80 °F (27 °C). Range = 54 to 100 °F (12 to 37.5 °C)
heat max	As per user. Default value = 90 °F (32 °C). Range = 40 to 90 °F (4.5 to 32.0 °C)
cool min	As per user. Default value = 54 °F (12 °C). Range = 54 to 100 °F (12 to 37.5 °C)
Pband	3 °F (1.2 °C) is factory set, range is: 2 to 10 °F (0.6 to 5.6 °C)
Set Type	Permanent
SptFunc	Dual Stp or AttchStp
TOccTime	As per user. Default value 2 hours. Range = 0 to 24 hours
DoorTime	N/A
deadband	As per user. Default value 2.0 °F (1.0 °C). Range = 2, 3, 4 or 5 °F, 1.0 °F increments (1.0 to 2.5 °C, 0.5 °C increments)
cal RS	0 °F or °C
cal RH	0 °F or °C
aux cont	0
Auto Fan	AS or AS AD
FL time	As per user. Default value = 1.5 minutes. Range 0.5 to 9.0 in 0.5 minutes increments
cph	As per user. 4 to 8 CPH
Reheat	0 for ON/OFF (4CPH), 1 for PWM (10 second)
UI3 dis	Displays supply air temperature

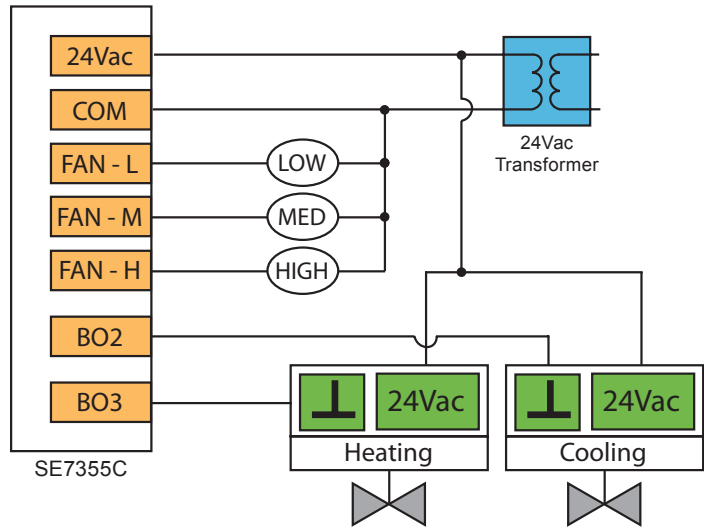

Sequence of Operation and Wiring

Occupied mode:

During occupied periods, the occupied heating and cooling setpoints are used.

PIR activated stand-by and unoccupied modes: When equipped with a PIR (Passive Infrared) accessory cover the controller provides advanced occupancy logic, which will automatically switch occupancy levels from occupied to stand-by to unoccupied when no motion is detected in the room.

- During PIR activated stand-by periods, the stand-by heating and cooling setpoints are used.
- During PIR activated unoccupied periods, the unoccupied-by heating and cooling setpoints are used.

Unoccupied mode:

During unoccupied periods, the unoccupied heating & cooling setpoints are used.

Local override:

The controller will revert back to the occupied mode as specified by a configuration timer when a local override is performed at the controller.

On a call for cooling:

The cooling valve will open according to demand. Dehumidification is authorized during cooling operation.

On a call for heating:

The heating valve will modulate from closed to open according to demand. Dehumidification is not authorized during heating operation.

Fan mode operation:

The 3 speed fan can be set to automatic speed on demand, or manually to low, medium or high speed.

On a demand for dehumidification:

Dehumidification is achieved via the cooling coil using the heating coil for reheat if necessary. Dehumidification is only allowed in COOL mode (or if cooling is enabled in AUTO mode). Dehumidification is disabled if the room temperature falls below the room low ambient dehumidification temperature.

Options

BACnet, Echelon and Wireless models are available. See Appendix B for details.

Remote wall mounted sensor or a return air temperature sensor can be used instead of the internal temperature sensor of the controller.

2 binary inputs and one universal input can be used and configured for advanced functionality as required by the application; e.g., discharge air sensor, door or window contact input, filter and service alarms, etc.

Other fan mode configurations can be set for either single speed, dual speed or three-speed fan mode operation.

SE7355C5045

Heating & cooling: Four-pipe fan coil unit with three-speed fan, tri-state floating valves and dehumidification sequence

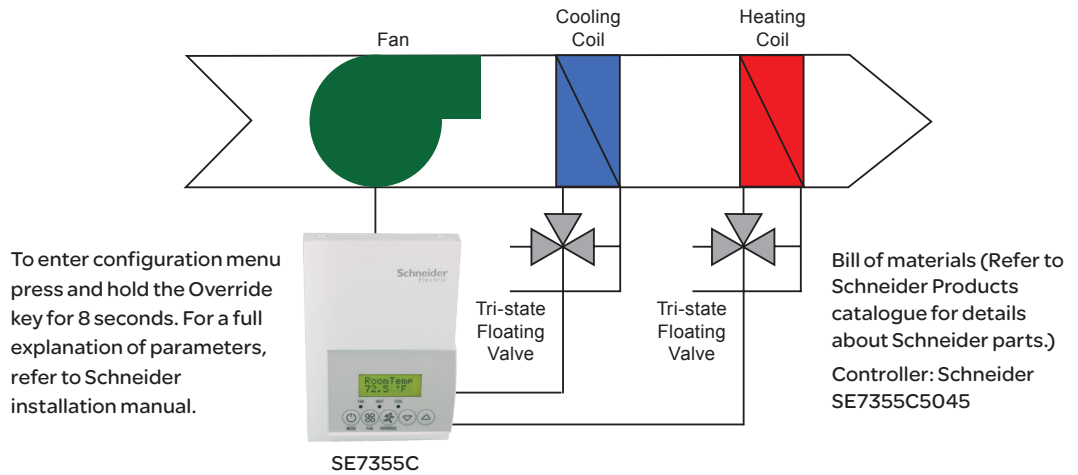

Parameter	Configuration Settings
PswrdSet	0 is factory set, range is: 0-1000
BI1	None
BI2	None
UI3	None
MenuScro	ON
AutoMode	ON
C or F	As per user. Default value = °F
%RH disp	ON
Lockout	As per user. Default value = 0 No lock
Pipe No	4.0
CntrlTyp	Floating
SeqOpera	4 = Cooling / Heating 4 pipes
Fan Menu	2
DHumiLCK	ON
%RH set	As per user. Default value = 50%. Range = 30% to 95%
DehuHyst	As per user. Default value = 5%. Range = 2% to 20%
DehuCool	As per user. Default value = 100%. Range = 20% to 100%
St-By TM	0.5 hours is factory set, range is: 0.0 to 24.0 hours in 0.5hr increments
Unocc TM	0.0 hours is factory set, range is: 0.0 to 24.0 hours in 0.5hr increments
St-By HT	69 °F (20.6 °C) is factory set, range is: 40 to 90 °F (4.5 to 32.0 °C)
St-By CL	78 °F (25.6 °C) is factory set, range is: 54 to 100 °F (12.0 to 37.5 °C)
Unocc HT	As per user. Default value = 62 °F (17 °C). Range = 40 to 90 °F (4.5 to 32.0 °C)
Unocc CL	As per user. Default value = 80 °F (27 °C). Range = 54 to 100 °F (12 to 37.5 °C)
heat max	As per user. Default value = 90 °F (32 °C). Range = 40 to 90 °F (4.5 to 32.0 °C)
cool min	As per user. Default value = 54 °F (12 °C). Range = 54 to 100 °F (12 to 37.5 °C)
Pband	3 °F (1.2 °C) is factory set, range is: 2 to 10 °F (0.6 to 5.6 °C)
Set Type	Permanent
SptFunc	Dual Stp or AttchStp
TOccTime	As per user. Default value 2 hours. Range = 0 to 24 hours
DoorTime	N/A
deadband	As per user. Default value 2.0 °F (1.0 °C). Range = 2, 3, 4 or 5 °F, 1.0 °F increments (1.0 to 2.5 °C, 0.5 °C increments)
cal RS	0 °F or °C
cal RH	0 °F or °C
aux cont	0
Auto Fan	AS or AS AD
FL time	As per user. Default value = 1.5 minutes. Range 0.5 to 9.0 in 0.5 minutes increments
cph	N/A
Reheat	0 for ON/OFF (4CPH), 1 for PWM (10 second)
UI3 dis	Displays supply air temperature

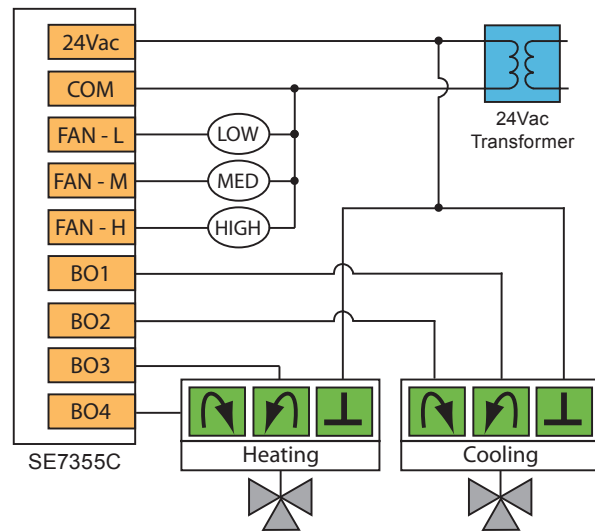

Sequence of Operation and Wiring

Occupied mode:

During occupied periods, the occupied heating and cooling setpoints are used.

PIR activated stand-by and unoccupied modes: When equipped with a PIR (Passive Infrared) accessory cover the controller provides advanced active occupancy logic, which will automatically switch occupancy levels from occupied to stand-by to unoccupied when no motion is detected in the room.

- During PIR activated stand-by periods, the stand-by heating and cooling setpoints are used.
- During PIR activated unoccupied periods, the unoccupied-by heating and cooling setpoints are used.

Unoccupied mode:

During unoccupied periods, the unoccupied heating & cooling setpoints are used.

Local override:

The controller will revert back to the occupied mode as specified by a configuration timer when a local override is requested at the controller.

On a call for cooling:

The cooling valve will open according to demand. Dehumidification is authorized during cooling operation.

On a call for heating:

The heating valve will modulate from closed to open according to demand. Dehumidification is not authorized during heating operation.

Fan mode operation:

The 3 speed fan can be set to automatic speed on demand, or manually to low, medium or high speed.

On a demand for dehumidification:

Dehumidification is achieved via the cooling coil using the heating coil for reheat if necessary. Dehumidification is only allowed in COOL mode (or if cooling is enabled in AUTO mode). Dehumidification is disabled if the room temperature falls below the room low ambient dehumidification temperature.

Options

BACnet, Echelon and Wireless models are available. See Appendix B for details.

Remote wall mounted sensor or a return air temperature sensor can be used instead of the internal temperature sensor of the controller.

2 binary inputs and one universal input can be used and configured for advanced functionality as required by the application; e.g., discharge air sensor, door or window contact input, filter and service alarms, etc.

Other fan mode configurations can be set for either single speed, dual speed or three-speed fan mode operation.

SE7355C5045

Heating & cooling: Single-compressor heat pump with two-speed fan and dehumidification sequence

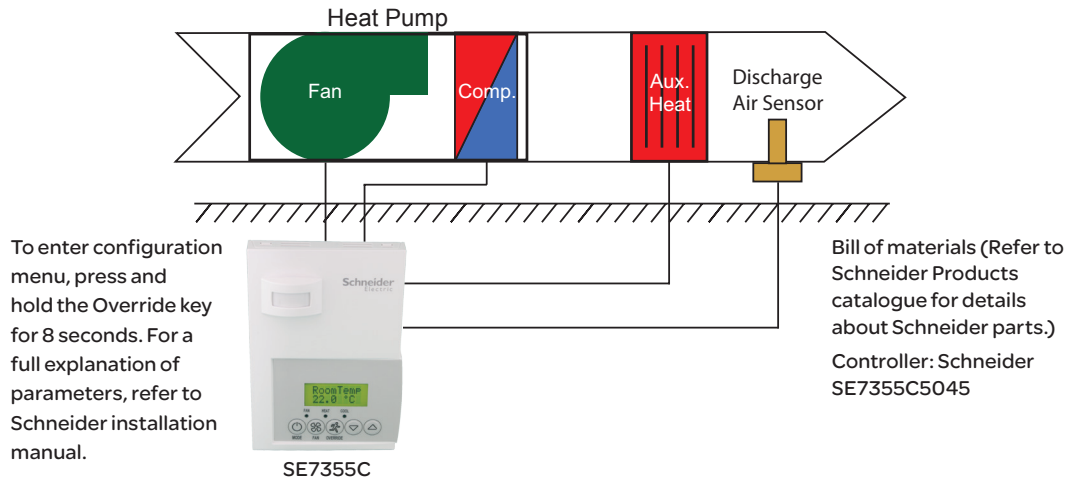

Parameter	Configuration Settings
PswrdSet	0 is factory set, range is: 0-1000
BI1	None
BI2	None
UI3	SS
MenuScro	ON
AutoMode	ON
C or F	As per user. Default value = °F
%RH disp	ON
Lockout	As per user. Default value = 0 No lock
Pipe No	4.0
CntrlTyp	ON/OFF
SeqOpera	5 = Cooling / Heating with Reheat 4 pipes
Fan Menu	1
DHumiLCK	ON
%RH set	As per user. Default value = 50%. Range = 30% to 95%
DehuHyst	As per user. Default value = 5%. Range = 2% to 20%
DehuCool	As per user. Default value = 100%. Range = 20% to 100%
St-By TM	0.5 hours is factory set, range is: 0.0 to 24.0 hours in 0.5hr increments
Unocc TM	0.0 hours is factory set, range is: 0.0 to 24.0 hours in 0.5hr increments
St-By HT	69 °F (20.6 °C) is factory set, range is: 40 to 90 °F (4.5 to 32.0 °C)
St-By CL	78 °F (25.6 °C) i is factory set, range is: 54 to 100 °F (12.0 to 37.5 °C)
Unocc HT	As per user. Default value = 62 °F (17 °C). Range = 40 to 90 °F (4.5 to 32.0 °C)
Unocc CL	As per user. Default value = 80 °F (27 °C). Range = 54 to 100 °F (12 to 37.5 °C)
heat max	As per user. Default value = 90 °F (32 °C). Range = 40 to 90 °F (4.5 to 32.0 °C)
cool min	As per user. Default value = 54 °F (12 °C). Range = 54 to 100 °F (12 to 37.5 °C)
Pband	3 °F (1.2 °C) is factory set, range is: 2 to 10 °F (0.6 to 5.6 °C)
Set Type	Permanent
SptFunc	Dual Stp or AttchStp
TOccTime	As per user. Default value 2 hours. Range = 0 to 24 hours
DoorTime	N/A
deadband	As per user. Default value 2.0 °F (1.0 °C). Range = 2, 3, 4 or 5 °F, 1.0 °F increments (1.0 to 2.5 °C, 0.5 °C increments)
cal RS	0 °F or °C
cal RH	0 °F or °C
aux cont	0
Auto Fan	AS or AS AD
FL time	N/A
cph	4
Reheat	0 for ON/OFF (4CPH), 1 for PWM (10 second)
UI3 dis	Displays supply air temperature

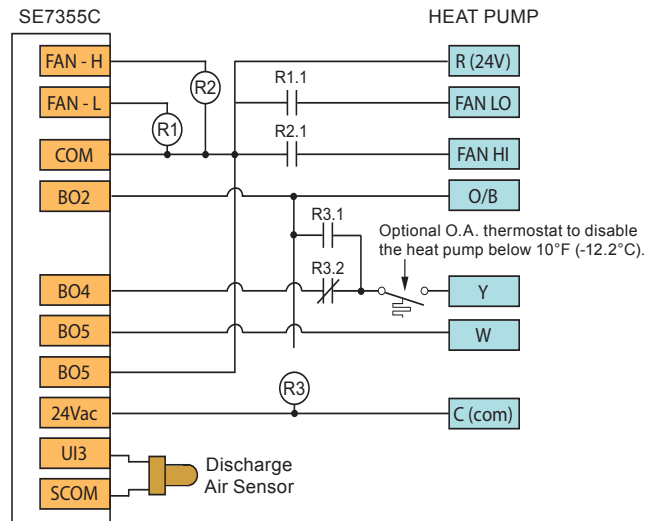

Sequence of Operation and Wiring

Occupied mode:

During occupied periods, the occupied heating and cooling setpoints are used.

PIR activated stand-by and unoccupied modes: When equipped with a PIR (Passive Infrared) accessory cover the controller provides advanced active occupancy logic, which will automatically switch occupancy levels from occupied to stand-by to unoccupied when no motion is detected in the room.

- During PIR activated stand-by periods, the stand-by heating and cooling setpoints are used.
- During PIR activated unoccupied periods, the unoccupied-by heating and cooling setpoints are used.

Unoccupied mode:

During unoccupied periods, the unoccupied heating & cooling setpoints are used.

Local override:

The controller will revert back to the occupied mode as specified by a configuration timer when a local override is requested at the controller.

On a call for cooling:

The heat pump relay will operate the heat pump compressor and activate the reversing valve according to demand. Dehumidification is authorized during cooling operation.

On a call for heating:

The heat pump relay will operate the heat pump compressor and deactivate the reversing valve according to demand. The duct heater will operate as a second step. Dehumidification is not authorized during heating operation.

Fan mode operation:

The 2 speed fan can be set either to automatic speed on demand or manually to either low or medium speed.

On a demand for dehumidification:

Dehumidification is achieved via the cooling coil using the heating coil for reheat if necessary. Dehumidification is only allowed in COOL mode (or if cooling is enabled in AUTO mode). Dehumidification is disabled if the room temperature falls below the room low ambient dehumidification temperature.

Options

BACnet, Echelon and Wireless models are available. See Appendix B for network wiring.

Analogue outputs available (*different models) .

Can be configured for 4 pipe systems.

Binary inputs can be configured to control occupancy via door or window contact, remote night setback or to provide alarms for service or filter monitoring.

Universal input can be configured for supply air monitoring / Remote wall mount or duct sensor ready.



Energy savings for a healthy bottom line.

Increase the comfort of patients, visitors, and employees while reducing energy consumption with SE7000 Series room controllers.



SE7600 Roof Top and Heat Pump Controllers

Products

1H Application: One electric heat coil and single speed fan	D-2
1H & 1C Roof Top unit: One heating stage and one cooling stage with single-speed fan	D-4
1H & 1C Roof Top unit: One heating stage, one cooling stage with differential pressure switch for filter alarm	D-6
2H & 2C Roof Top unit: Two heating stages and two cooling stages with single-speed fan	D-8
2H & 2C Roof Top unit: Two heating stages, two cooling stages with differential pressure switch for filter alarm	D-10
2H & 2C Roof Top unit with economizer: Two heating & two cooling stages, analogue 0-10Vdc fresh air damper actuator & sensor averaging	D-12
1H & 1C Heat pump: One compressor for heat/cool	D-14
3H & 2C Heat pump: Two compressors for heat/cool and electric duct heater	D-16
1H & 1C 4-Pipe fan coil unit: Two-position heating and cooling valves, single-speed fan and dehumidification sequence	D-18
2H & 2C Roof Top unit with humidification: Two heating stages, two cooling stages, analogue 0-10Vdc humidifier and differential pressure switch for filter alarm	D-20

SE7600A5045

1H Application: One electric heat coil and single-speed fan

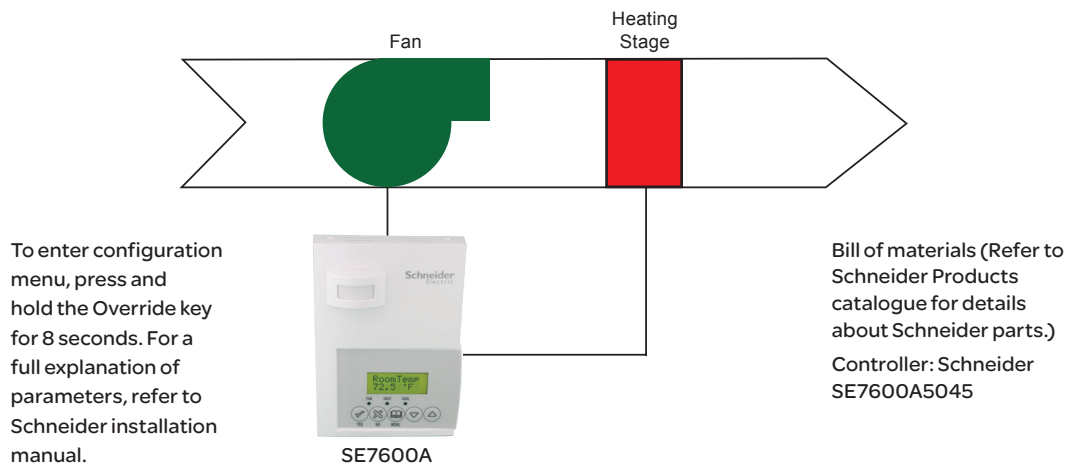

Parameter	Configuration Settings
PswrdSet	0 is factory set, range is: 0-1000
DI1	None
DI2	None
Lockout	As per user: (see manual for details) set to "0" for full access
pwr del	10 seconds is factory set, range is: 10 to 120 seconds
Frost pr	ON
Heat max	90 °F (32 °C) is factory set, range is: 40 to 90 °F (4.5 to 32.0 °C)
Cool min	54 °F (12 °C) is factory set, range is: 54 to 100 °F (12.0 to 37.5 °C)
Pband	3 °F (1.2 °C) is factory set, range is: 2 to 10 °F (0.6 to 5.6 °C)
anticycle	2 minutes is factory set range is: 0,1,2,3,4 & 5 minutes
Heat cph	4 C.P.H is factory set, range is: 3, 4, 5, 6,7 & 8 C.P.H.
Cool cph	4 C.P.H. is factory set, range is: 3 or 4 C.P.H.
deadband	As per user. Default value 2.0 °F (1.0 °C). Range = 2, 3, 4 or 5 °F, 1.0 °F increments (1.0 to 2.5 °C, 0.5 °C increments)
fan cont	ON, Auto or Smart (see manual for details)
Fan del	OFF
ToccTime	3 hours is factory default, range is: 0 to 12 in one hour increments
cal RS	0.0 °F or °C
cal OS	0.0 °F or °C
H lock	120 °F (49 °C) is factory default, range is: -15 °F up to 120 °F (-26 °C up to 49 °C)
C lock	-40 °F (-40 °C) is factory default, range is: From -40 °F up to 95 °F (-40 °C up to 35 °C)
Unocc TM	0.5 hours is factory set, range is: 0.5 to 24.0 hours in 0.5hr increments
2/4event	2 events is factory default, can also be set to 4 event
Aux cont	N.O. or N.C.
Prog rec	ON

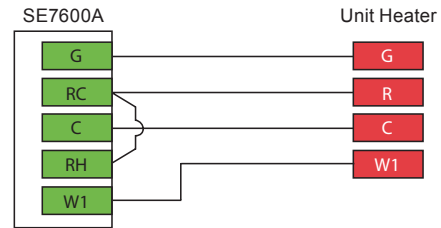

Sequence of Operation and Wiring

Occupied mode:

During occupied periods, the occupied heating and cooling setpoints are used.

PIR activated unoccupied mode: When equipped with a PIR (Passive Infrared) accessory cover the controller provides advanced active occupancy logic, which will automatically switch occupancy levels from occupied to unoccupied when no motion is detected in the room. During PIR activated unoccupied periods, the unoccupied-by heating and cooling setpoints are used.

Unoccupied mode:

During unoccupied periods, the unoccupied heating & cooling setpoints are used.

Local override:

The controller will revert back to the occupied mode as specified by a configuration timer when a local override is requested at the controller.

On a call for heating:

The heating stage will operate according to demand.

Fan mode operation:

The single-speed fan can be set to either automatic on demand or always on.

Options

BACnet, Echelon and Wireless models are available. See Appendix B for details.

Remote wall mounted sensor or a return air temperature sensor can be used instead of the internal temperature sensor of the controller.

One monitoring supply air temperature input and two digital inputs can be used and configured for advanced functionality if required by the application; e.g., remote night setback, remote override, filter and service alarms, etc.

An outdoor temperature input can be used and configured for the lockout of heating and cooling operation.

SE7600A5045

1H & 1C Roof top unit: One heating stage
and one cooling stage with single-speed fan

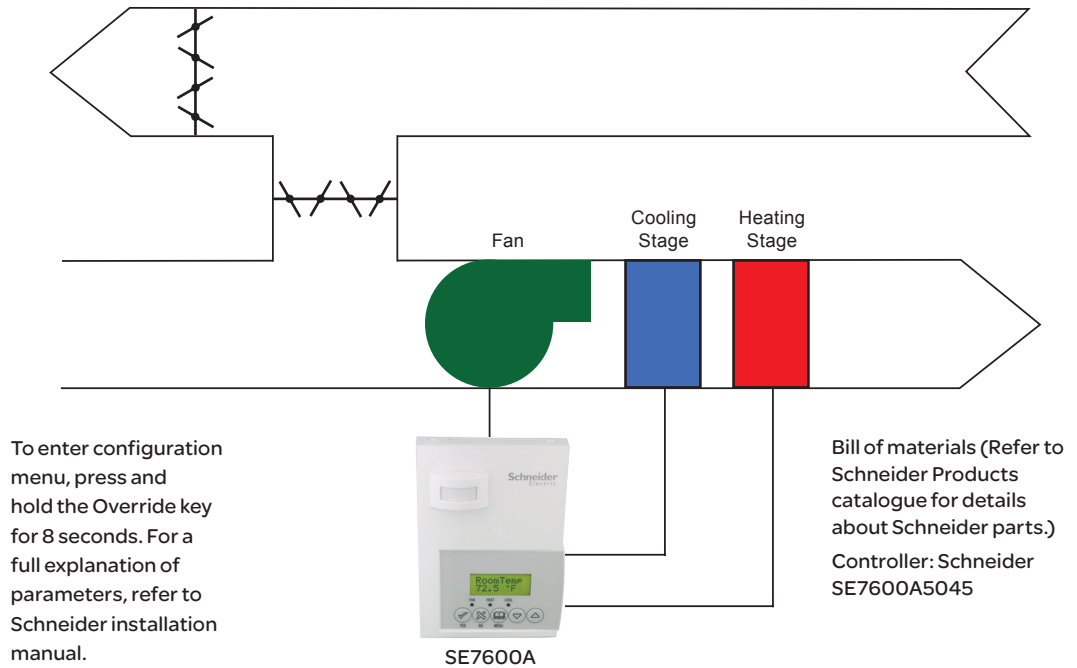

Parameter	Configuration Settings
PswrdSet	0 is factory set, range is: 0-1000
DI1	None
DI2	None
Lockout	As per user: (see manual for details) set to "0" for full access
pwr del	10 seconds is factory set, range is: 10 to 120 seconds
Frost pr	ON
Heat max	90 °F (32 °C) is factory set, range is: 40 to 90 °F (4.5 to 32.0 °C)
Pband	3 °F (1.2 °C) is factory set, range is: 2 to 10 °F (0.6 to 5.6 °C)
Cool min	54 °F (12 °C) is factory set, range is: 54 to 100 °F (12.0 to 37.5 °C)
anticycle	2 minutes is factory set range is: 0,1,2,3,4 & 5 minutes
Heat cph	4 C.P.H is factory set, range is: 3, 4, 5, 6,7 & 8 C.P.H.
Cool cph	4 C.P.H. is factory set, range is: 3 or 4 C.P.H.
deadband	As per user. Default value 2.0 °F (1.0 °C). Range = 2, 3, 4 or 5 °F, 1.0 °F increments (1.0 to 2.5 °C, 0.5 °C increments)
fan cont	ON, Auto or Smart (see manual for details)
Fan del	OFF
TocctTime	3 hours is factory default, range is: 0 to 12 in one hour increments
cal RS	0.0 °F or °C
cal OS	0.0 °F or °C
H lock	120 °F (49 °C) is factory default, range is: -15 °F up to 120 °F (-26 °C up to 49 °C)
C lock	-40 °F (-40 °C) is factory default, range is: From -40 °F up to 95 °F (-40 °C up to 35 °C)
Unocc TM	0.5 hours is factory set, range is: 0.5 to 24.0 hours in 0.5hr increments
2/4event	2 events is factory default, can also be set to 4 event
Aux cont	N.O. or N.C.
Prog rec	ON

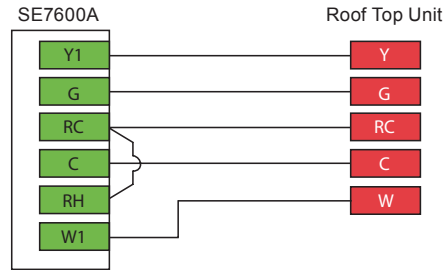

Sequence of Operation and Wiring

Occupied mode:

During occupied periods, the occupied heating and cooling setpoints are used.

PIR activated unoccupied mode: When equipped with a PIR (Passive Infrared) accessory cover the controller provides advanced active occupancy logic, which will automatically switch occupancy levels from occupied to unoccupied when no motion is detected in the room. During PIR activated unoccupied periods, the unoccupied-by heating and cooling setpoints are used.

Unoccupied mode:

During unoccupied periods, the unoccupied heating & cooling setpoints are used.

Local override:

The controller will revert back to the occupied mode as specified by a configuration timer when a local override is requested at the controller.

On a call for cooling:

The cooling stage will operate according to demand.

On a call for heating:

The heating stage will operate according to demand.

Fan mode operation:

The single-speed fan can be set to either automatic on demand or always on.

Options

BACnet, Echelon and Wireless models are available. See Appendix B for details.

Remote wall mounted sensor or a return air temperature sensor can be used instead of the internal temperature sensor of the controller.

One monitoring supply air temperature input and two digital inputs can be used and configured for advanced functionality if required by the application; e.g., remote night setback, remote override, filter and service alarms, etc.

An outdoor temperature input can be used and configured for the lockout of heating and cooling operation.

SE7652A5045

1H & 1C Roof top unit: One heating stage, one cooling stage with differential pressure switch for filter alarm

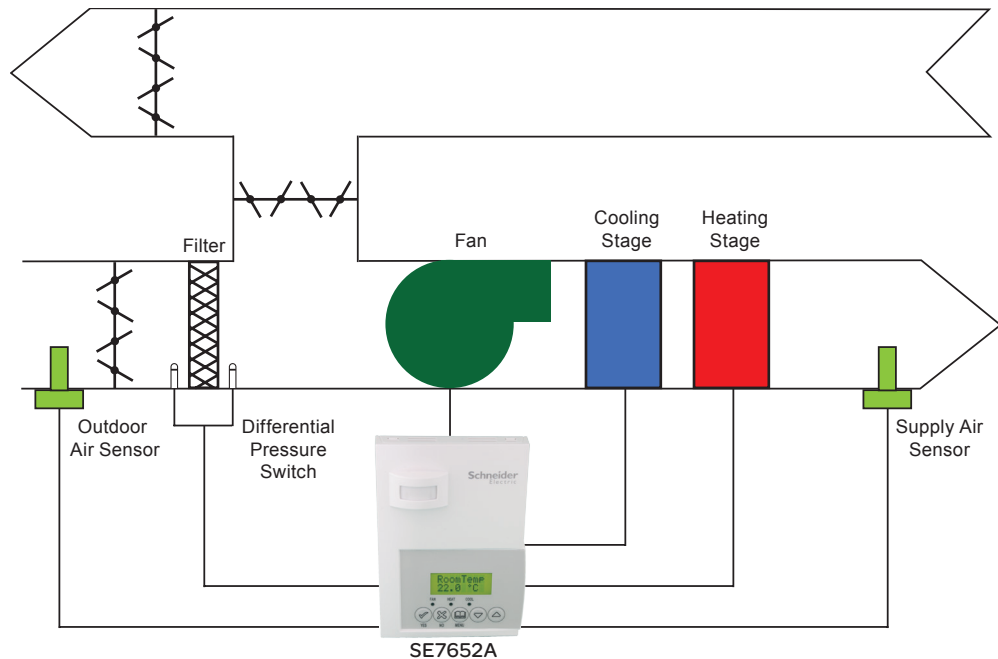

To enter configuration menu, press and hold the Override key for 8 seconds. For a full explanation of parameters, refer to Schneider installation manual.

SE7652A

Bill of materials (Refer to Schneider Products catalogue for details about Schneider parts.)
Controller: Schneider SE7652A5045

Parameter	Configuration Settings
PswrdSet	0 is factory set, range is: 0-1000
DI1	Filter
DI2	None
Lockout	As per user: (see manual for details) set to "0" for full access
pwr del	10 seconds is factory set, range is: 10 to 120 seconds
Frost pr	ON
Heat max	90 °F (32 °C) is factory set, range is: 40 to 90 °F (4.5 to 32.0 °C)
Cool min	54 °F (12 °C) is factory set, range is: 54 to 100 °F (12.0 to 37.5 °C)
Pband	3 °F (1.2 °C) is factory set, range is: 2 to 10 °F (0.6 to 5.6 °C)
anticycle	2 minutes is factory set range is: 0,1,2,3,4 & 5 minutes
Heat cph	4 C.P.H is factory set, range is: 3, 4, 5, 6,7 & 8 C.P.H.
Cool cph	4 C.P.H. is factory set, range is: 3 or 4 C.P.H.
deadband	As per user. Default value 2.0 °F (1.0 °C). Range = 2, 3, 4 or 5 °F, 1.0 °F increments (1.0 to 2.5 °C, 0.5 °C increments)
fan cont	ON, Auto or Smart (see manual for details)
Fan del	OFF
ToccTime	3 hours is factory default, range is: 0 to 12 in one hour increments
cal RS	0.0 °F or °C
cal OS	0.0 °F or °C
H lock	120 °F (49 °C) is factory default, range is: -15 °F up to 120 °F (-26 °C up to 49 °C)
C lock	-40 °F (-40 °C) is factory default, range is: From -40 °F up to 95 °F (-40 °C up to 35 °C)
Unocc TM	0.5 hours is factory set, range is: 0.5 to 24.0 hours in 0.5hr increments
2/4event	2 events is factory default, can also be set to 4 event
Aux cont	N.O. or N.C.
Prog rec	ON

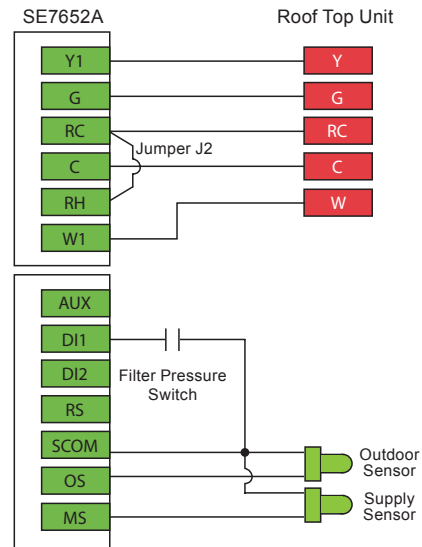

Sequence of Operation and Wiring

Local schedule:

A local schedule (7 days, 2 or 4 events) internal to the controller is used to trigger the different occupancy levels of the controller.

Occupied mode:

During occupied periods, the occupied heating and cooling setpoints are used.

PIR activated unoccupied mode: When equipped with a PIR (Passive Infrared) accessory cover the controller provides advanced active occupancy logic, which will automatically switch occupancy levels from occupied to unoccupied when no motion is detected in the room. During PIR activated unoccupied periods, the unoccupied-by heating and cooling setpoints are used.

Unoccupied mode:

During unoccupied periods, the unoccupied heating & cooling setpoints are used.

Local override:

The controller will revert back to the occupied mode as specified by a configuration timer when a local override is requested at the controller.

On a call for cooling:

The cooling stage will operate according to demand.

On a call for heating:

The heating stage will operate according to demand.

Fan mode operation:

The single-speed fan can be set to either automatic on demand or always on mode.

Filter alarm: When the filter must be cleaned, the differential pressure switch will close the contact on DI1 input and a local alarm will be displayed.

Options

BACnet, Echelon and Wireless models are available. See Appendix B for details.

Remote wall mounted sensor or a return air temperature sensor can be used instead of the internal temperature sensor of the controller.

One monitoring supply air temperature input and two digital inputs can be used and configured for advanced functionality if required by the application; e.g., remote night setback, remote override, filter and service alarms, etc.

SE7600B5045

2H & 2C Roof top unit: Two heating stages and two cooling stages with single-speed fan

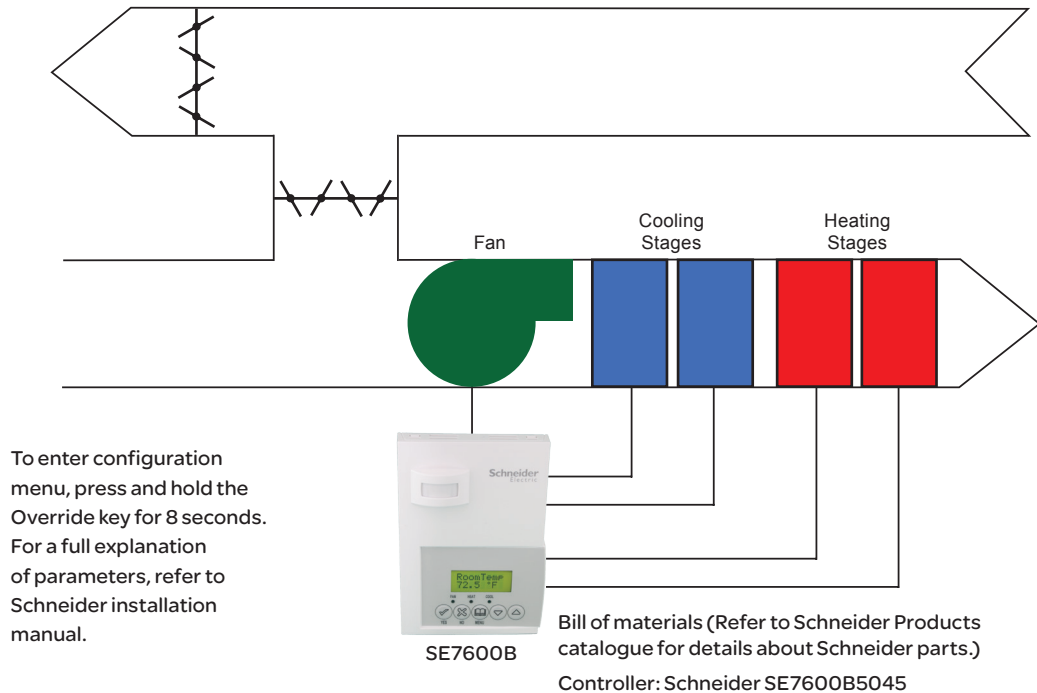

Parameter	Configuration Settings
PswrdSet	0 is factory set, range is: 0-1000
DI1	None
DI2	None
Lockout	As per user: (see manual for details) set to "0" for full access
pwr del	10 seconds is factory set, range is: 10 to 120 seconds
Frost pr	ON
Heat max	90 °F (32 °C) is factory set, range is: 40 to 90 °F (4.5 to 32.0 °C)
Cool min	54 °F (12 °C) is factory set, range is: 54 to 100 °F (12.0 to 37.5 °C)
Pband	3 °F (1.2 °C) is factory set, range is: 2 to 10 °F (0.6 to 5.6 °C)
anticycle	2 minutes is factory set range is: 0,1,2,3,4 & 5 minutes
Heat cph	4 C.P.H is factory set, range is: 3, 4, 5, 6,7 & 8 C.P.H.
Cool cph	4 C.P.H. is factory set, range is: 3 or 4 C.P.H.
deadband	As per user. Default value 2.0 °F (1.0 °C). Range = 2, 3, 4 or 5 °F, 1.0 °F increments (1.0 to 2.5 °C, 0.5 °C increments)
fan cont	ON, Auto or Smart (see manual for details)
Fan del	OFF
Tocctime	3 hours is factory default, range is: 0 to 12 in one hour increments
cal RS	0.0 °F or °C
cal OS	0.0 °F or °C
H stage	2
C stage	2
H lock	120 °F (49 °C) is factory default, range is: -15 °F up to 120 °F (-26 °C up to 49 °C)
C lock	-40 °F (-40 °C) is factory default, range is: From -40 °F up to 95 °F (-40 °C up to 35 °C)
Unocc TM	0.5 hours is factory set, range is: 0.5 to 24.0 hours in 0.5hr increments
2/4event	2 events is factory default, can also be set to 4 event
Aux cont	N.O. or N.C.
Prog rec	ON

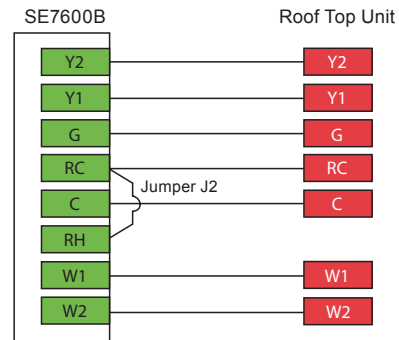

Sequence of Operation and Wiring

Local schedule:

A local schedule (7 days, 2 or 4 events) internal to the controller is used to trigger the different occupancy levels of the controller.

Occupied mode:

During occupied periods, the occupied heating and cooling setpoints are used.

PIR activated unoccupied mode: When equipped with a PIR (Passive Infrared) accessory cover the controller provides advanced active occupancy logic, which will automatically switch occupancy levels from occupied to unoccupied when no motion is detected in the room. During PIR activated unoccupied periods, the unoccupied-by heating and cooling setpoints are used.

Unoccupied mode:

During unoccupied periods, the unoccupied heating & cooling setpoints are used.

Local override:

The controller will revert back to the occupied mode as specified by a configuration timer when a local override is requested at the controller.

On a call for cooling:

The cooling stages will operate according to demand.

On a call for heating:

The heating stage will operate according to demand.

Fan mode operation:

The single-speed fan can be set to either automatic on demand or always on.

Options

BACnet, Echelon and Wireless models are available. See Appendix B for details.

Remote wall mounted sensor or a return air temperature sensor can be used instead of the internal temperature sensor of the controller.

One monitoring supply air temperature input and two digital inputs can be used and configured for advanced functionality if required by the application; e.g., remote night setback, remote override, filter and service alarms, etc.

An outdoor temperature input can be used and configured for the lockout of heating and cooling operation.

SE7652B5045

2H & 2C Roof top unit: Two heating stages, two cooling stages with differential pressure switch for filter alarm

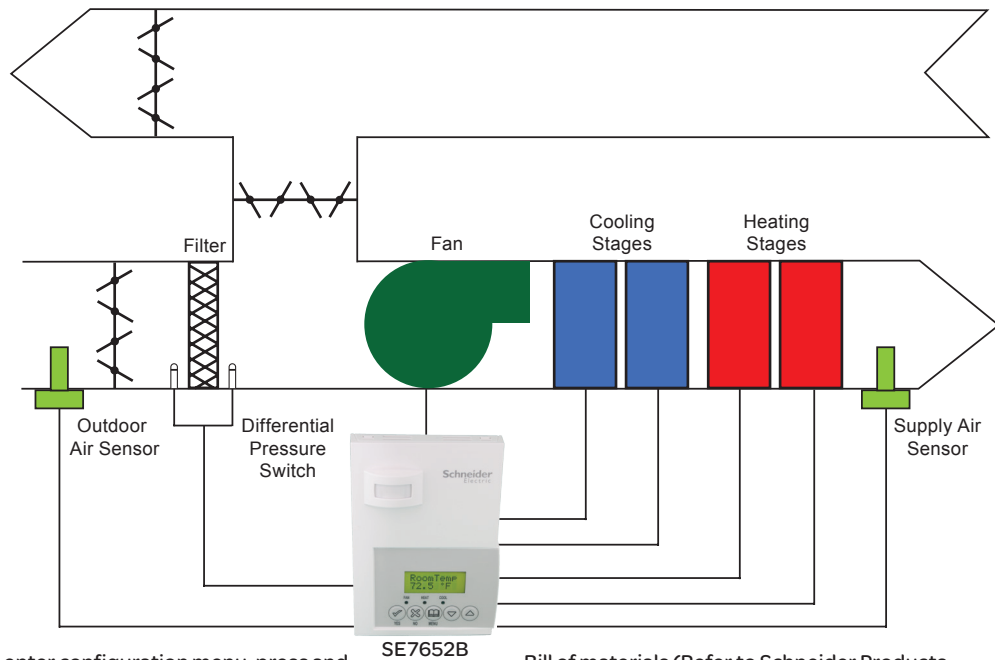

To enter configuration menu, press and hold the Override key for 8 seconds. For a full explanation of parameters, refer to Schneider installation manual.

SE7652B

Bill of materials (Refer to Schneider Products catalogue for details about Schneider parts.)
Controller: Schneider SE7652B5045

Parameter	Configuration Settings
PswrdSet	0 is factory set, range is: 0-1000
DI1	Filter
DI2	None
Lockout	As per user: (see manual for details) set to "0" for full access
pwr del	10 seconds is factory set, range is: 10 to 120 seconds
Frost pr	ON
Heat max	90 °F (32 °C) is factory set, range is: 40 to 90 °F (4.5 to 32.0 °C)
Cool min	54 °F (12 °C) is factory set, range is: 54 to 100 °F (12.0 to 37.5 °C)
Pband	3 °F (1.2 °C) is factory set, range is: 2 to 10 °F (0.6 to 5.6 °C)
anticycle	2 minutes is factory set range is: 0,1,2,3,4 & 5 minutes
Heat cph	4 C.P.H is factory set, range is: 3, 4, 5, 6,7 & 8 C.P.H.
Cool cph	4 C.P.H. is factory set, range is: 3 or 4 C.P.H.
deadband	As per user. Default value 2.0 °F (1.0 °C). Range = 2, 3, 4 or 5 °F, 1.0 °F increments (1.0 to 2.5 °C, 0.5 °C increments)
fan cont	ON, Auto or Smart (see manual for details)
Fan del	OFF
ToccTime	3 hours is factory default, range is: 0 to 12 in one hour increments
cal RS	0.0 °F or °C
cal OS	0.0 °F or °C
H stage	2 stages is factory default, range is: 1 or 2 stages
C stage	2 stages is factory default, range is: 1 or 2 stages
H lock	120 °F (49 °C) is factory default, range is: -15 °F up to 120 °F (-26 °C up to 49 °C)
C lock	-40 °F (-40 °C) is factory default, range is: From -40 °F up to 95 °F (-40 °C up to 35 °C)
Unocc TM	0.5 hours is factory set, range is: 0.5 to 24.0 hours in 0.5hr increments
2/4event	2 events is factory default, can also be set to 4 event
Aux cont	N.O. or N.C.
Prog rec	ON

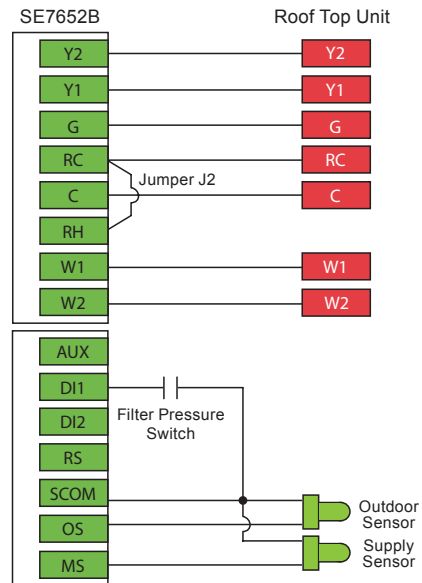

Sequence of Operation and Wiring

Supply air sensing:

A supply air sensor is used for remote monitoring of the discharge air temperature of the HVAC equipment.

Local schedule:

A local schedule (7 days, 2 or 4 events) internal to the controller is used to trigger the different occupancy levels of the controller.

Occupied mode:

During occupied periods, the occupied heating and cooling setpoints are used.

PIR activated unoccupied mode: When equipped with a PIR (Passive Infrared) accessory cover the controller provides advanced active occupancy logic, which will automatically switch occupancy levels from occupied to unoccupied when no motion is detected in the room. During PIR activated unoccupied periods, the unoccupied-by heating and cooling setpoints are used.

Unoccupied mode:

During unoccupied periods, the unoccupied heating & cooling setpoints are used.

Local override:

The controller will revert back to the occupied mode as specified by a configuration timer when a local override is requested at the controller.

On a call for cooling:

If the outdoor air temperature allows for economizer-free cooling operation:

The first stage of cooling is outdoor-air-free cooling and will maintain a low limit mixed air set point.

The mechanical cooling stages will operate as second and third cooling stages, based on demand.

If the outdoor air temperature does not allow for economizer-free cooling operation, the cooling stages will operate according to demand.

On a call for heating:

The heating stage will operate according to demand.

Fan mode operation:

The single-speed fan can be set to either automatic on demand or always on.

Filter alarm: When the filter must be cleaned, the differential pressure switch will close the contact on DI1 input and a local alarm will be displayed.

Options

BACnet, Echelon and Wireless models are available. See Appendix B for details.

Remote wall mounted sensor or a return air temperature sensor can be used instead of the internal temperature sensor of the controller.

One monitoring supply air temperature input and two digital inputs can be used and configured for advanced functionality if required by the application; e.g., remote night setback, remote override, filter and service alarms, etc.

SE7656B5045

2H & 2C Roof top unit with economizer: Two heating & two cooling stages, analogue 0-10Vdc fresh air damper actuator & sensor averaging

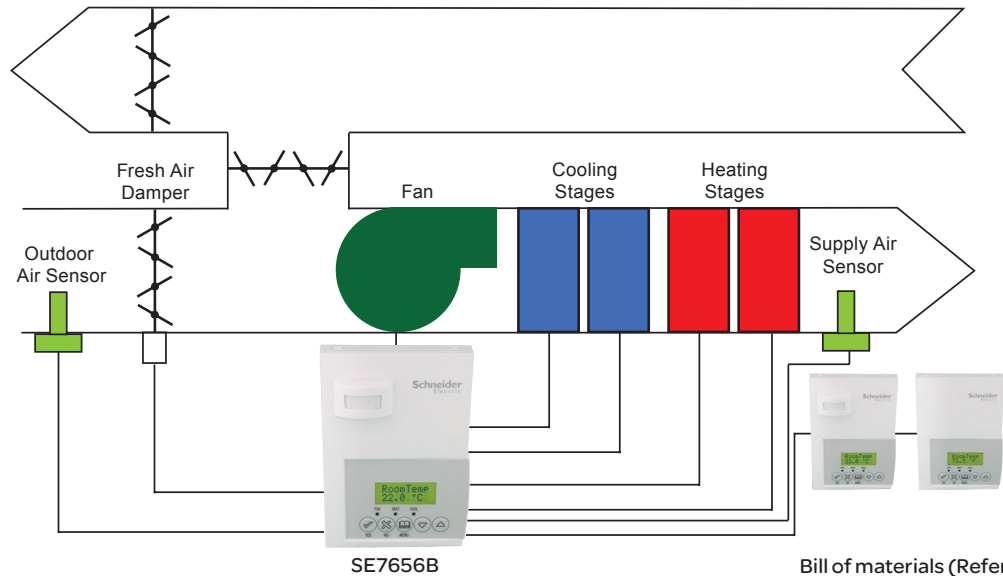

Configuration menu: press and hold Override key 8 seconds. For explanation of parameters refer to Schneider installation manual.

Bill of materials (Refer to Schneider Products catalogue for details about Schneider parts.)

Parameter	Configuration Settings
PswrdSet	0 is factory set, range is: 0-1000
DI1	Filter
DI2	None
Lockout	As per user: (see manual for details) set to "0" for full access
pwr del	10 seconds is factory set, range is: 10 to 120 seconds
Frost pr	ON
Heat max	90 °F (32 °C) is factory set, range is: 40 to 90 °F (4.5 to 32.0 °C)
Cool min	54 °F (12 °C) is factory set, range is: 54 to 100 °F (12.0 to 37.5 °C)
Pband	3 °F (1.2 °C) is factory set, range is: 2 to 10 °F (0.6 to 5.6 °C)
anticycle	2 minutes is factory set range is: 0,1,2,3,4 & 5 minutes
Heat cph	4 C.P.H is factory set, range is: 3, 4, 5, 6,7 & 8 C.P.H.
Cool cph	4 C.P.H. is factory set, range is: 3 or 4 C.P.H.
deadband	As per user. Default value 2.0 °F (1.0 °C). Range = 2, 3, 4 or 5 °F, 1.0 °F increments (1.0 to 2.5 °C, 0.5 °C increments)
fan cont	ON, Auto or Smart (see manual for details)
Fan del	OFF
Com Addr	Found on BACnet models only
ToccTime	3 hours is factory default, range is: 0 to 12 in one hour increments
cal RS	0.0 °F or °C
cal OS	0.0 °F or °C
H stage	2 stages
C stage	2 stages
H lock	120 °F (49 °C) is factory default, range is: -15 °F up to 120 °F (-26 °C up to 49 °C)
C lock	-40 °F (-40 °C) is factory default, range is: From -40 °F up to 95 °F (-40 °C up to 35 °C)
Unocc TM	0.5 hours is factory set, range is: 0.5 to 24.0 hours in 0.5hr increments
2/4event	2 events is factory default, can also be set to 4 event
Aux cont	N.O. normally open
Prog rec	ON
chngst pt	55 °F (13.0 °C) is default value, range is:14 to 70 °F (-10.0 to 21.0 °C)
Min pos	0% is factory default, range is: 0 to 100%
C mech	ON
mix stpt	55 °F (13.0 °C) is factory default, range is: 50 to 90 °F (10.0 to 32.0 °C)

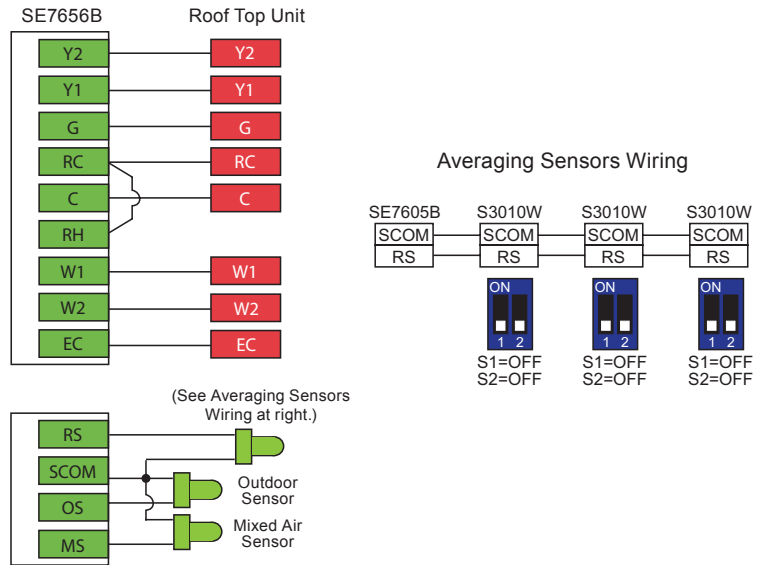

Sequence of Operation and Wiring

Supply air sensing:

A supply air sensor is used for remote monitoring of the discharge air temperature of the HVAC equipment.

Local schedule:

A local schedule (7 days, 2 or 4 events) internal to the controller is used to trigger the different occupancy levels of the controller.

Occupied mode:

During occupied periods, the occupied heating and cooling setpoints are used. The minimum position of the economizer fresh air damper is enabled.

PIR activated unoccupied mode: When equipped with a PIR (Passive Infrared) accessory cover the controller provides advanced active occupancy logic, which will automatically switch occupancy levels from occupied to unoccupied when no motion is detected in the room. During PIR activated unoccupied periods, the unoccupied-by heating and cooling setpoints are used. The minimum position of the economizer fresh air damper is disabled.

Unoccupied mode:

During unoccupied periods, the unoccupied heating & cooling setpoints are used. The minimum position of the economizer fresh air damper is disabled.

Local override:

The controller will revert back to the occupied mode as specified by a configuration timer when a local override is requested at the controller.

On a call for cooling:

The cooling stages will operate according to demand.

On a call for heating:

The compressor output will operate the heat pump compressor and de-energize the reversing valve according to demand.

Fan mode operation:

The single-speed fan can be set to either automatic on demand or always on.

Options

BACnet, Echelon and Wireless models are available. See Appendix B for details.

Remote wall mounted sensor or a return air temperature sensor can be used instead of the internal temperature sensor of the controller.

One monitoring supply air temperature input and two digital inputs can be used and configured for advanced functionality if required by the application; e.g., remote night setback, remote override, filter and service alarms, etc.

SE7652H5045

1H & 1C Heat pump: One compressor
for heat/cool

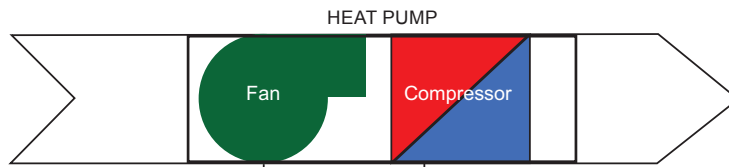

To enter configuration menu, press and hold the Override key for 8 seconds. For a full explanation of parameters, refer to Schneider installation manual.



SE7652H

Bill of materials (Refer to Schneider Products catalogue for details about Schneider parts.)
Controller: Schneider SE7652H5045

Parameter	Configuration Settings
PswrdSet	0 is factory set, range is: 0-1000
DI1	None
DI2	None
Lockout	As per user: (see manual for details) set to "0" for full access
pwr del	10 seconds is factory set, range is: 10 to 120 seconds
Frost pr	ON
Heat max	90 °F (32 °C) is factory set, range is: 40 to 90 °F (4.5 to 32.0 °C)
Cool min	54 °F (12 °C) is factory set, range is: 54 to 100 °F (12.0 to 37.5 °C)
Pband	3 °F (1.2 °C) is factory set, range is: 2 to 10 °F (0.6 to 5.6 °C)
anticycle	2 minutes is factory set range is: 0,1,2,3,4 & 5 minutes
Heat cph	4 C.P.H is factory set, range is: 3, 4, 5, 6,7 & 8 C.P.H.
Cool cph	4 C.P.H. is factory set, range is: 3 or 4 C.P.H.
deadband	As per user. Default value 2.0 °F (1.0 °C). Range = 2, 3, 4 or 5 °F, 1.0 °F increments (1.0 to 2.5 °C, 0.5 °C increments)
fan cont	ON, Auto or Smart (see manual for details)
Fan del	OFF
ToccTime	3 hours is factory default, range is: 0 to 12 in one hour increments
cal RS	0.0 °F or °C
cal OS	0.0 °F or °C
HP stage	1 stage
H lock	120 °F (49 °C) is factory default, range is: -15 °F up to 120 °F (-26 °C up to 49 °C)
C lock	-40 °F (-40 °C) is factory default, range is: From -40 °F up to 95 °F (-40 °C up to 35 °C)
Unocc TM	0.5 hours is factory set, range is: 0.5 to 24.0 hours in 0.5hr increments
2/4event	2 events is factory default, can also be set to 4 events
Aux cont	N.O. normally open
Prog rec	OFF
high bp	90 °F (32.0 °C) is default value, range is: 34 to 90 °F (1.0 to 32.0 °C)
low bp	-12 °F (-24.0 °C) is default value, range is: -40 to 30 °F (-40.0 to -1.0 °C)
comf/eco	Comfort mode or Economy mode
re valve	O when reversing valve energized in cooling or B when energized in heating
Comp/aux	OFF

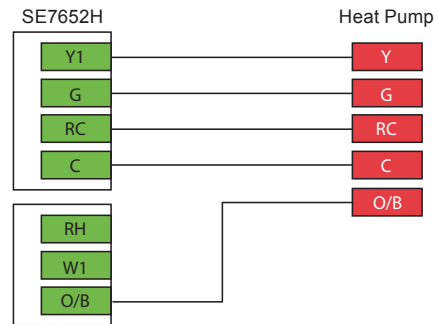

Sequence of Operation and Wiring

Occupied mode:

During occupied periods, the occupied heating and cooling setpoints are used.

PIR activated unoccupied mode: When equipped with a PIR (Passive Infrared) accessory cover the controller provides advanced active occupancy logic, which will automatically switch occupancy levels from occupied to unoccupied when no motion is detected in the room. During PIR activated unoccupied periods, the unoccupied-by heating and cooling setpoints are used.

Unoccupied mode:

During unoccupied periods, the unoccupied heating & cooling setpoints are used.

Local override:

The controller will revert back to the occupied mode as specified by a configuration timer when a local override is requested at the controller.

On a call for cooling:

The compressor output will operate the heat pump compressor and energize the reversing valve according to demand.

On a call for heating:

The compressor output will operate the heat pump compressor stages and de-energize the reversing valve according to demand. The duct heater will operate as a third step.

Fan mode operation:

The single-speed fan can be set to either automatic on demand or always on.

Options

BACnet, Echelon and Wireless models are available. See Appendix B for details.

Remote wall mounted sensor or a return air temperature sensor can be used instead of the internal temperature sensor of the controller.

One monitoring supply air temperature input and two digital inputs can be used and configured for advanced functionality if required by the application; e.g., remote night setback, remote override, filter and service alarms, etc.

An outdoor temperature input can be used and configured for the lockout of heating and cooling operation.

SE7652H5045

3H & 2C Heat pump: Two compressors for heat/cool and electric duct heater

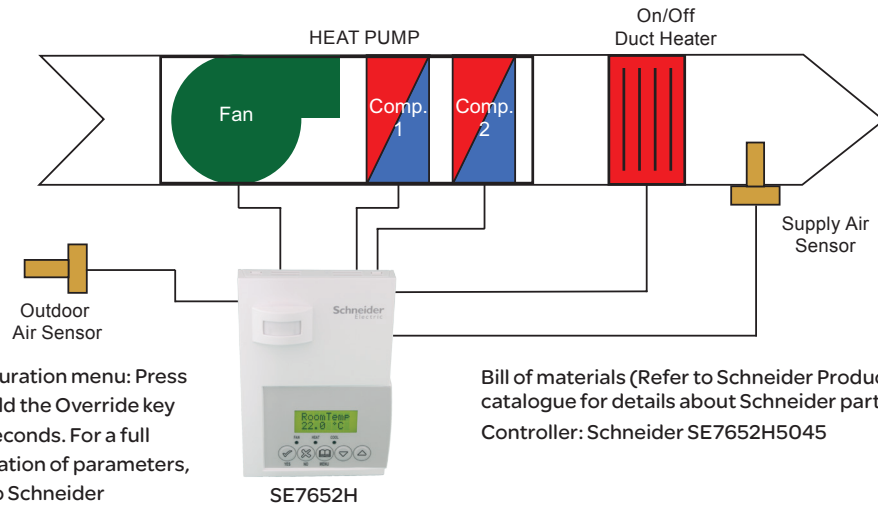

Parameter	Configuration Settings
PswrdSet	0 is factory set, range is: 0-1000
DI1	Filter
DI2	None
Lockout	As per user: (see manual for details) set to "0" for full access
pwr del	10 seconds is factory set, range is: 10 to 120 seconds
Frost pr	ON
Heat max	90 °F (32 °C) is factory set, range is: 40 to 90 °F (4.5 to 32.0 °C)
Cool min	54 °F (12 °C) is factory set, range is: 54 to 100 °F (12.0 to 37.5 °C)
Pband	3 °F (1.2 °C) is factory set, range is: 2 to 10 °F (0.6 to 5.6 °C)
anticycle	2 minutes is factory set range is: 0,1,2,3,4 & 5 minutes
Heat cph	4 C.P.H is factory set, range is: 3, 4, 5, 6,7 & 8 C.P.H.
Cool cph	4 C.P.H. is factory set, range is: 3 or 4 C.P.H.
deadband	As per user. Default value 2.0 °F (1.0 °C). Range = 2, 3, 4 or 5 °F, 1.0 °F increments (1.0 to 2.5 °C, 0.5 °C increments)
fan cont	ON, Auto or Smart (see manual for details)
Fan del	OFF
Com Addr	Found on BACnet models only
TocTime	3 hours is factory default, range is: 0 to 12 in one hour increments
cal RS	0.0 °F or °C
cal OS	0.0 °F or °C
H stage	2 stages
HP stage	2 stages
H lock	120 °F (49 °C) is factory default, range is: -15 °F up to 120 °F (-26 °C up to 49 °C)
C lock	-40 °F (-40 °C) is factory default, range is: From -40 °F up to 95 °F (-40 °C up to 35 °C)
Unocc TM	0.5 hours is factory set, range is: 0.5 to 24.0 hours in 0.5hr increments
2/4event	2 events is factory default, can also be set to 4 event
Aux cont	N.O. normally open
Prog rec	ON
high bp	90 °F (32.0 °C) is default value, range is:34 to 90 °F (1.0 to 32.0 °C)
low bp	-12 °F (-24.0 °C) is default value, range is:-40 to 30 °F (-40.0 to -1.0 °C)
comf/eco	Comfort mode or Economy mode
re valve	O when reversing valve energized in cooling or B when energized in heating
Comp/aux	OFF

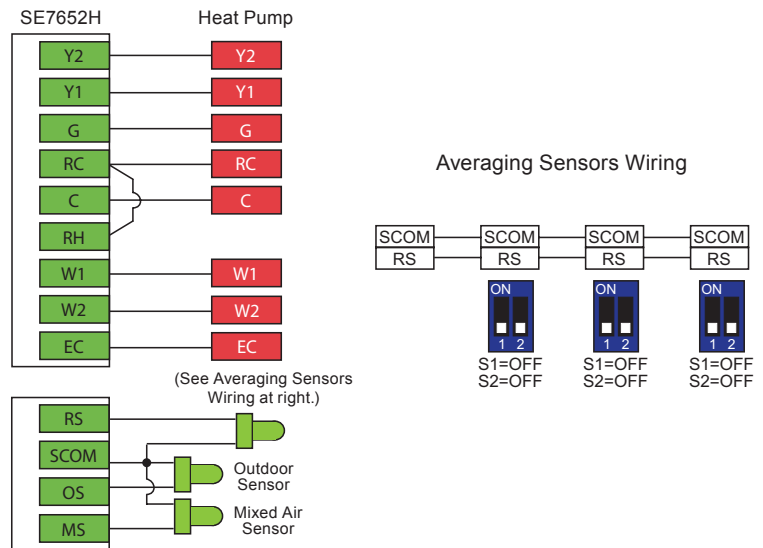

Sequence of Operation and Wiring

Supply air sensing:

A supply air sensor monitors the discharge air temperature of the HVAC unit.

Local schedule:

A local schedule (7 days, 2 or 4 events) internal to the controller is used to trigger the different occupancy levels of the controller.

Occupied mode:

During occupied periods, the occupied heating and cooling setpoints are used.

PIR activated unoccupied mode: When equipped with a PIR (Passive Infrared) accessory cover, the controller provides advanced active occupancy logic which will automatically switch occupancy levels from occupied to unoccupied when no motion is detected in the room. During PIR activated unoccupied periods, the unoccupied-by heating and cooling setpoints are used.

Unoccupied mode:

During unoccupied periods, the unoccupied heating & cooling setpoints are used.

Local override:

The controller will revert back to the occupied mode as specified by a configuration timer when a local override is requested at the controller.

On a call for cooling:

If the outdoor air temperature allows for economizer-free cooling operation:

The first stage of cooling is outdoor-air-free cooling and will maintain a low limit mixed air set point.

The mechanical cooling stages will operate as second and third cooling stages, based on demand.

If the outdoor air temperature does not allow for economizer-free cooling operation, the cooling stages will operate according to demand.

On a call for heating:

The compressor output operates the heat pump compressor stages and de-energizes the reversing valve per demand. Duct heater operates as a third step.

Fan mode operation:

The single-speed fan can be set to either automatic on demand or always on.

Filter alarm: When the filter must be cleaned, the differential pressure switch will close the contact on DI1 input and a local alarm will be displayed.

Options

BACnet, Echelon and Wireless models are available. See Appendix B for details.

Remote wall mounted sensor or a return air temperature sensor can be used instead of the internal temperature sensor of the controller.

One monitoring supply air temperature input and two digital inputs can be used and configured for advanced functionality if required by the application; e.g., remote night setback, remote override, filter and service alarms, etc.

An outdoor temperature input can be used and configured for the lockout of heating and cooling operation.

SE7657B5045

1H & 1C 4-Pipe fan coil unit: Two-position heating and cooling valves, single speed fan and dehumidification sequence

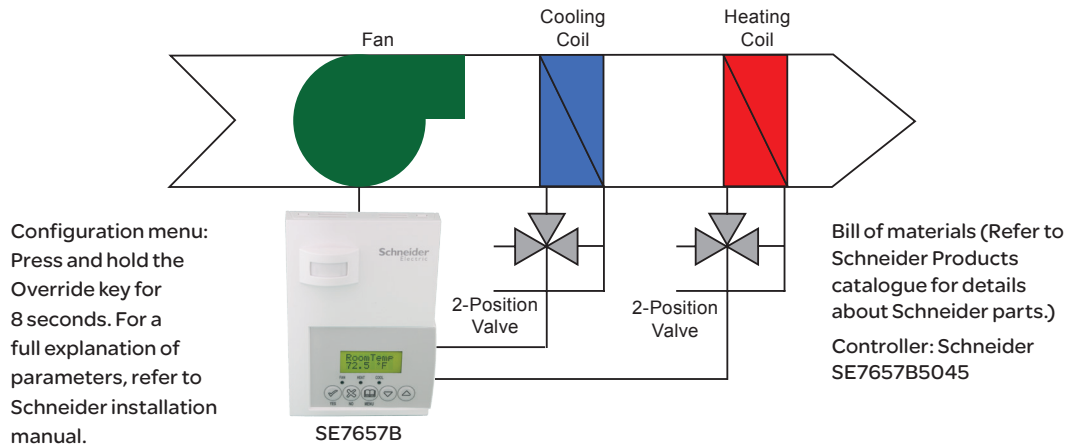

Parameter	Configuration Settings
PswrdSet	0 is factory set, range is: 0-1000
%RH disp	
DI	None
Lockout	As per user: (see manual for details) set to "0" for full access
pwr del	10 seconds is factory set, range is: 10 to 120 seconds
Frost pr	ON
Heat max	90 °F (32 °C) is factory set, range is: 40 to 90 °F (4.5 to 32.0 °C)
Cool min	54 °F (12 °C) is factory set, range is: 54 to 100 °F (12.0 to 37.5 °C)
Pband	3 °F (1.2 °C) is factory set, range is: 2 to 10 °F (0.6 to 5.6 °C)
anticycle	2 minutes is factory set range is: 0,1,2,3,4 & 5 minutes
Heat cph	4 C.P.H is factory set, range is: 3, 4, 5, 6,7 & 8 C.P.H.
Cool cph	4 C.P.H. is factory set, range is: 3 or 4 C.P.H.
deadband	As per user. Default value 2.0 °F (1.0 °C). Range = 2, 3, 4 or 5 °F, 1.0 °F increments (1.0 to 2.5 °C, 0.5 °C increments)
fan cont	ON, Auto or Smart (see manual for details)
Fan del	OFF
Com Addr	Found on BACnet models only
ToccTime	3 hours is factory default, range is: 0 to 12 in one hour increments
cal RS	0.0 °F or °C
cal OS	0.0 °F or °C
H stage	1 stages
C stage	1 stages
H lock	120 °F (49 °C) is factory default, range is: -15 °F up to 120 °F (-26 °C up to 49 °C)
C lock	-40 °F (-40 °C) is factory default, range is: -40 °F up to 95 °F (-40 °C up to 35 °C)
Unocc TM	0.5 hours is factory set, range is: 0.5 to 24.0 hours in 0.5hr increments
2/4event	2 events is factory default, can also be set to 4 event
Aux cont	N.O. normally open
Prog rec	ON
RH LT	-20 °F (-29 °C) is factory set, range is: -40 to 15 °F (-40 to -9.5 °C)
RH HT	32 °F (0 °C) is factory set, range is: 20 to 55 °F (-6.5 to 13 °C)
HL Sp	85% RH is factory default, range is: 50% RH to 90% RH
Dhu LCK	Off
Dhu OALK	32 °F (0 °C) is factory default, range is: -40 °F up to 122 °F (-40 °C up to 50 °C)
DehuHyst	5% RH is factory default, range is: 2% RH to 20% RH
RE Sp	20% RH is factory default, range is: 10% RH to 90% RH
RH cal	0% RH is factory default, range is: -15% RH to 15% RH
Display HL	Used as diagnostic

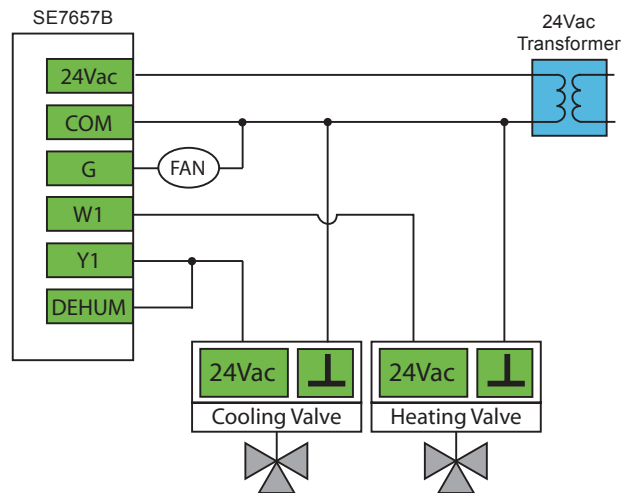

Sequence of Operation and Wiring

Occupied mode:

During occupied periods, the occupied heating and cooling setpoints are used.

PIR activated stand-by and unoccupied modes: When equipped with a PIR (Passive Infrared) accessory cover the controller provides advanced active occupancy logic, which will automatically switch occupancy levels from occupied to unoccupied when no motion is detected in the room. During PIR activated unoccupied periods, the unoccupied-by heating and cooling setpoints are used.

Unoccupied mode:

During unoccupied periods, the unoccupied heating & cooling setpoints are used.

Local override:

The controller will revert back to the occupied mode as specified by a configuration timer when a local override is requested at the controller.

On a call for cooling:

The cooling valve will open according to demand. Dehumidification is authorized during cooling operation.

On a call for heating:

The heating valve will modulate from closed to open according to demand. Dehumidification is not authorized during heating operation.

Fan mode operation:

The single speed fan can be set to either automatic on demand or always on.

On a demand for dehumidification:

Dehumidification is achieved via the cooling coil using the heating coil for reheat if necessary. Dehumidification is only allowed in COOL mode (or if cooling is enabled in AUTO mode). Dehumidification is disabled if the room temperature falls below the room low-ambient dehumidification temperature.

Note: This application is not recommended with DX mechanical cooling.

Options

BACnet, Echelon and Wireless models are available. See Appendix B for network wiring.

One digital inputs can be used and configured for advanced functionality if required by the application; e.g., remote night setback, remote override, filter and service alarms, etc.

An outdoor temperature input can be used and configured for the lockout of heating and cooling operation, alarms for service or filter monitor.

SE7657B5045

2H & 2C Roof top unit: Two heating stages, two cooling stages, analogue 0-10Vdc humidifier and differential pressure switch for filter alarm

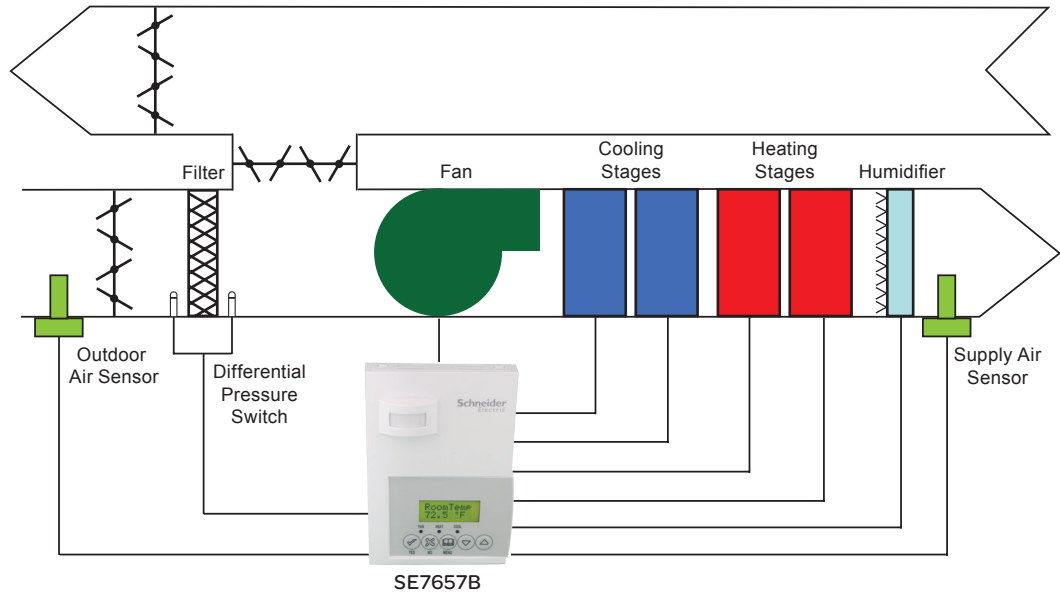

Configuration menu: Press and hold Override key 8 seconds. For explanation of parameters refer to Schneider installation manual.

Bill of materials (Refer to Schneider Products catalogue for details about Schneider parts.)
Controller: Schneider SE7657B5045

Parameter	Configuration Settings
PswrdSet	0 is factory set, range is: 0-1000
%RH disp	
DI	None
Lockout	As per user: (see manual for details) set to "0" for full access
pwr del	10 seconds is factory set, range is: 10 to 120 seconds
Frost pr	ON
Heat max	90 °F (32 °C) is factory set, range is: 40 to 90 °F (4.5 to 32.0 °C)
Cool min	54 °F (12 °C) is factory set, range is: 54 to 100 °F (12.0 to 37.5 °C)
Pband	3 °F (1.2 °C) is factory set, range is: 2 to 10 °F (0.6 to 5.6 °C)
anticycle	2 minutes is factory set range is: 0,1,2,3,4 & 5 minutes
Heat cph	4 C.P.H is factory set, range is: 3, 4, 5, 6,7 & 8 C.P.H.
Cool cph	4 C.P.H. is factory set, range is: 3 or 4 C.P.H.
deadband	As per user. Default value 2.0 °F (1.0 °C). Range = 2, 3, 4 or 5 °F, 1.0 °F increments (1.0 to 2.5 °C, 0.5 °C increments)
fan cont	ON, Auto or Smart (see manual for details)
Fan del	OFF
Com Addr	Found on BACnet models only
TocCTime	3 hours is factory default, range is: 0 to 12 in one hour increments
cal RS	0.0 °F or °C
cal OS	0.0 °F or °C
H stage	2 stages
C stage	2 stages
H lock	120 °F (49 °C) is factory default, range is: -15 °F up to 120 °F (-26 °C up to 49 °C)
C lock	-40 °F (-40 °C) is factory default, range is: -40 °F up to 95 °F (-40 °C up to 35 °C)
Unocc TM	0.5 hours is factory set, range is: 0.5 to 24.0 hours in 0.5hr increments
2/4event	2 events is factory default, can also be set to 4 event
Aux cont	N.O. normally open
Prog rec	ON
RH LT	-20 °F (-29 °C) is factory set, range is: -40 to 15 °F (-40 to -9.5 °C)
RH HT	32 °F (0 °C) is factory set, range is: 20 to 55 °F (-6.5 to 13 °C)
HL Sp	85% RH is factory default, range is: 50% RH to 90% RH
Dhu OALK	32 °F (0 °C) is factory default, range is: -40 °F up to 122 °F (-40 °C up to 50 °C)
DehuHyst	5% RH is factory default, range is: 2% RH to 20% RH
RE Sp	20% RH is factory default, range is: 10% RH to 90% RH
RH cal	0% RH is factory default, range is: -15% RH to 15% RH
Display HL	Used as diagnostic

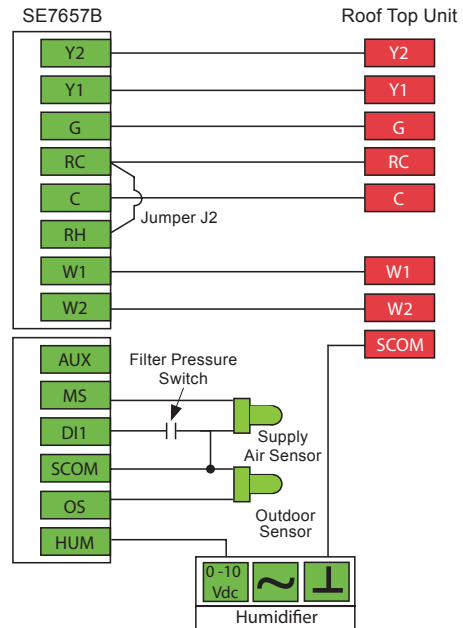

Sequence of Operation and Wiring

Supply air sensing:

A supply air sensor monitors the discharge air temperature of the HVAC unit.

Local schedule:

A local schedule (7 days, 2 or 4 events) internal to the controller is used to trigger the different occupancy levels of the controller.

Occupied mode:

During occupied periods, the occupied heating and cooling setpoints are used.

PIR activated stand-by and unoccupied modes: When equipped with a PIR (Passive Infrared) accessory cover the controller provides advanced active occupancy logic, which will automatically switch occupancy levels from occupied to unoccupied when no motion is detected in the room. During PIR activated unoccupied periods, the unoccupied-by heating and cooling setpoints are used.

Unoccupied mode:

During unoccupied periods, the unoccupied heating & cooling setpoints are used.

Local override:

The controller will revert back to the occupied mode as specified by a configuration timer when a local override is requested at the controller.

On a call for cooling:

The cooling stage will operate according to demand.

On a call for heating:

The heating valve will modulate from closed to open according to demand. Dehumidification is not authorized during heating operation.

Fan mode operation:

The single speed fan can be set to either automatic on demand or always on.

On a call for humidification:

The humidification proportional output (HUM) will be energized to modulate the humidifier.

Filter alarm: When the filter must be cleaned, the differential pressure switch will close the contact on DI1 input and a local alarm will be displayed.

Options

BACnet, Echelon and Wireless models are available. See Appendix B for network wiring.

One digital input can be used and configured for advanced functionality if required by the application; e.g., remote night setback, remote override, filter and service alarms, etc.

An outdoor temperature input can be used and configured for the lockout of heating and cooling operation, alarms for service or filter monitor.

Schneider Electric SE7000 Series room controllers offer simple yet elegant high-performance product features that deliver proven solutions to existing mid-market opportunities with the added benefit of providing significant energy savings.

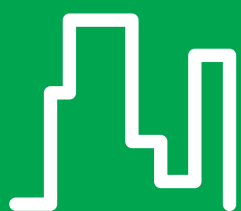

Building



Efficient control



Green energy

Products

Appendix A - Passive Infrared (PIR) Motion Detector Covers - Technical Specifications	E-2
Appendix B - Optional Network Wiring if for Communication Models Use	E-3
Appendix C - Controllers' Occupancy Sequence of Operation Schematic	E-5

Appendix A

Passive Infrared (PIR) Motion Detector Covers - Technical Specifications

APPENDIX A - PASSIVE INFRA-RED SENSOR

Sequence of Operation

Initially, the Room Controller is in Stand-by mode and Stand-by setpoints are used. When the Passive Infra-Red (PIR) sensor detects motion, the Occupancy status switches to Occupied and the Stand-By Time timer is reset. The Occupied setpoints are used for this operation. If no motion is detected in the room for the entire Stand-By Time duration (adjustable parameter), the room switches to Stand-by mode and Stand-by setpoints are used. While in Stand-by mode, if no motion is detected for the entire Unoccupied Time period (adjustable parameter), the room switches to Unoccupied mode and uses its Unoccupied setpoints. While in Stand-By or Unoccupied mode, any motion switches the room back to Occupied mode.

PIR ranges measure 20 feet (6 meters) at 120° and 15 feet (4.5 meters) minimum between 15° to 30° laterally. A typical installation height of approximately 5 feet (1.5 meters) is considered in these measurements.

The below illustrates the resolution.

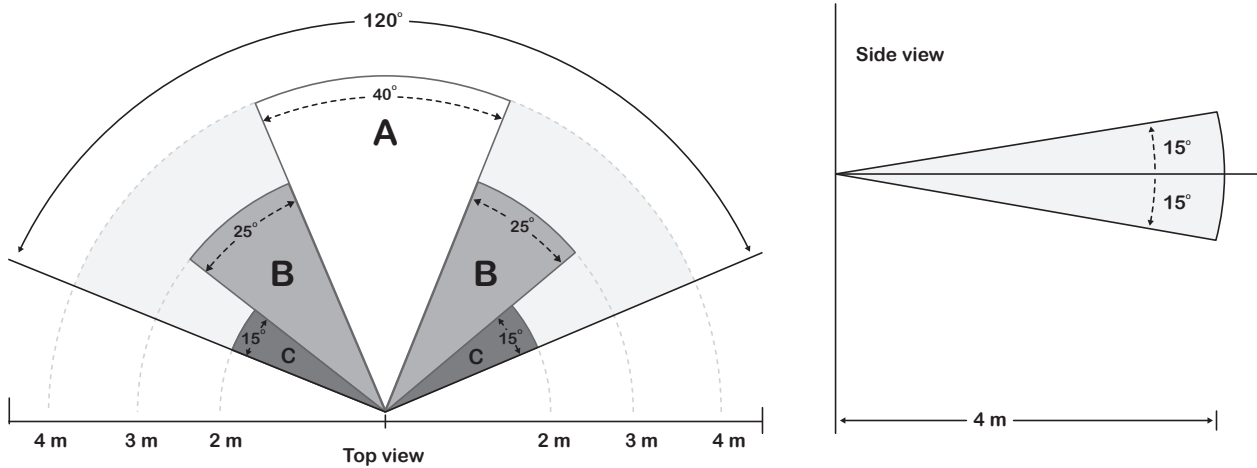

Fresnel lens beam and detection field

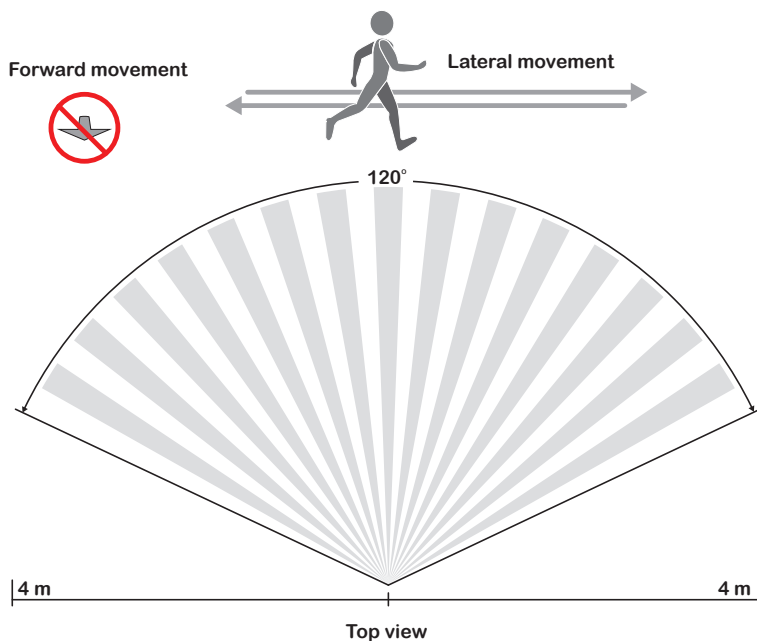

Energy Savings

PIR can maximize your energy saving from 10-30% by adjusting temperature set points in unoccupied zones during scheduled periods.

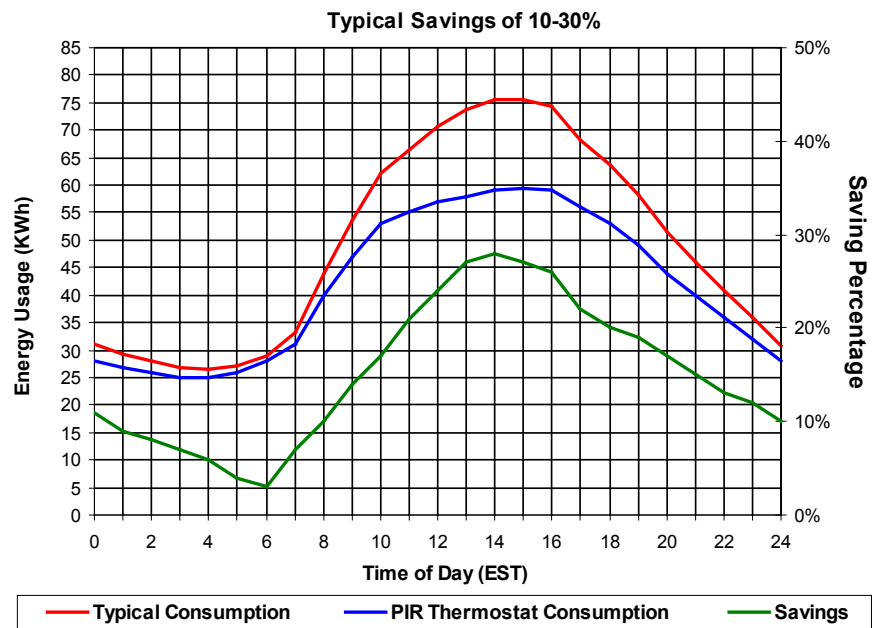

Deployment

Placement of the Room Controller must be given consideration. It is recommended to install the Room Controller as close to a door as possible (but not so as to be blocked by the door), or in an area with high occupant movement.

Ideally the Room Controller should be installed 5 feet (1.5 meters) above the floor surface to ensure maximum detection range is achieved. As well, Room Controller placement should ensure the occupant crosses the lens beam in a perpendicular path within the prescribed detection zone.

Example of Recommended Deployment

The below shows Room Controllers installed in ideal locations for two rooms.

The examination room shows one Room Controller installed adjacent to the door. In this area of the room, occupant traffic is high and ensures the occupant will almost always cross the PIR detection path laterally and within the detection range.

The waiting room shows one Room Controller installed beside a door in the middle of the room. As shown in the diagram below,

occupant traffic is high in several areas of the room including the entrance, waiting room, access to the door and activity around the

reception desk. Moreover, for each case aforementioned, occupant movement almost always moves lateral to the PIR, which ensures detection by the PIR, as well as respecting the PIR detection range of 20 feet (6 meters) at 120°, and 15 feet (4.5 meters) between 15° to 30° laterally.

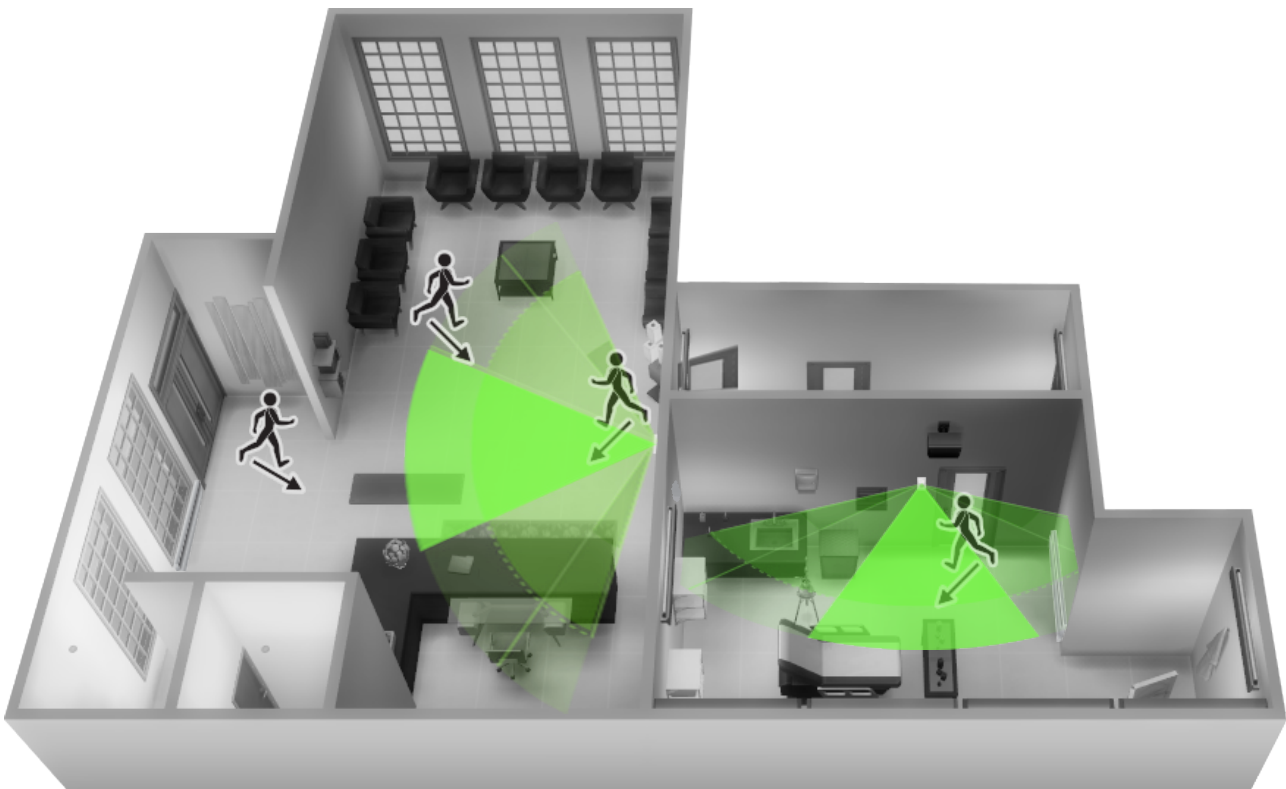

Recommended Installation

Example of Non-Recommended Deployment

The below shows four Room Controllers (two for each room) installed in non-ideal locations for the two rooms.

The examination room shows one Room Controller installed in a low traffic area near the door, and a second Room Controller installed on the wall directly opposite the door. For the Room Controller installed in the corner wall, the PIR could be blocked by the opened door, while occupant traffic could also be minimal in this area of the room. For the second Room Controller installed opposite the door, the PIR detection could fall outside the specified detection zone, while at the same time most occupant movement would be lateral to the PIR, thereby not respecting optimal crossing patterns for PIR detection.

The waiting room shows one Room Controller installed in the corner of the room, and a second Room Controller installed beside the reception area. For the Room Controller installed in the corner, the opening/closing of the door creates high probability that the PIR would get blocked, and therefore, occupancy going undetected. For the Room Controller installed beside the reception area, occupant traffic could fall outside the detection zone, and the receptionist would often be below the 5 foot recommended installation height for the Room Controller.

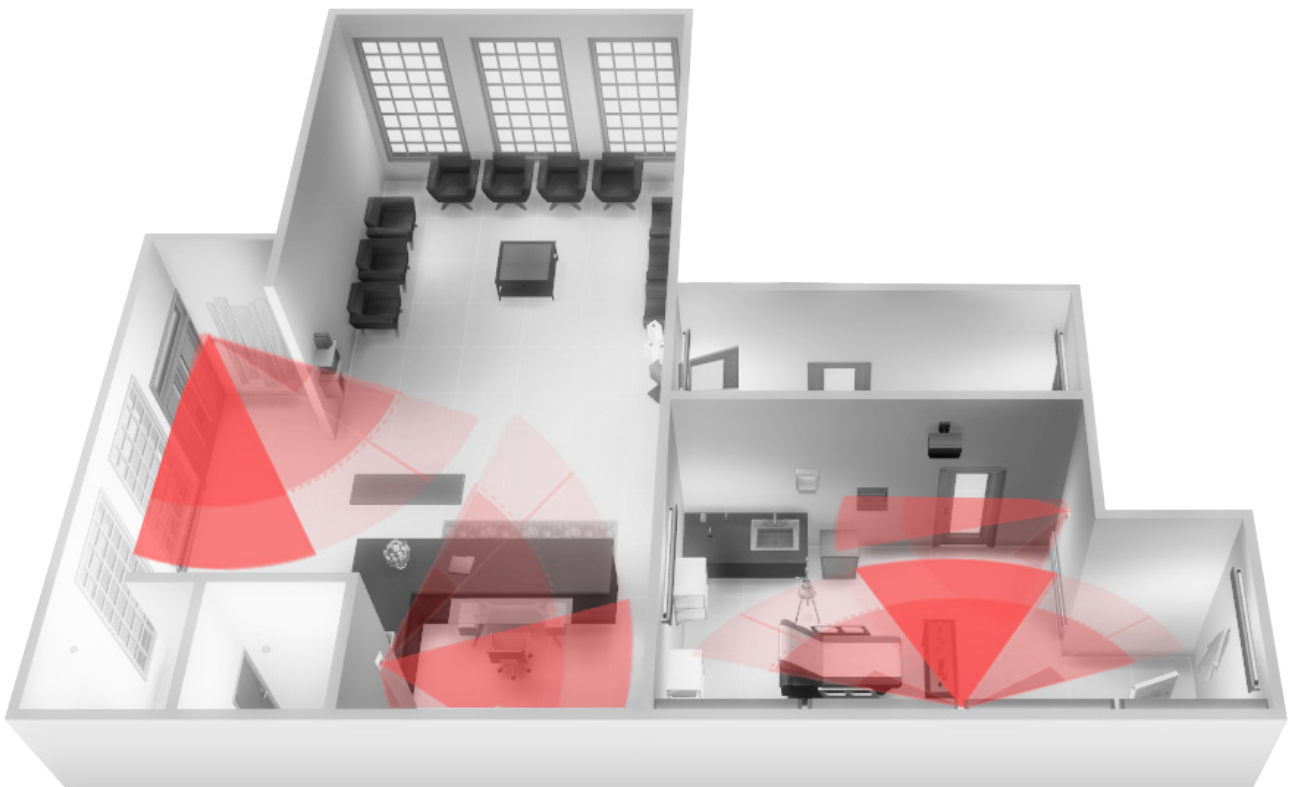

Non-Recommended Installation

Controller Wiring - Basic Layouts

BACnet Communication Wiring

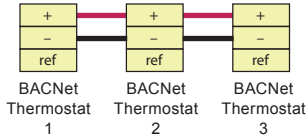

Echelon Communication Wiring

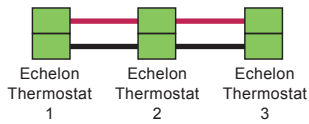

Wiring Notes:

- Wiring should be daisy chained.
- Respect polarity.
- If using 2 conductors shielded wires, connect the shield of each feed together on the back of the controller. Ground the shield at only **one** location. DO NOT connect the shield to the ref terminal.
- If using 2 conductors shielded wires, use the same connections as above but you may wire the 3rd conductor to the ref terminal for troubleshooting purposes.

Wireless accessories

Wireless integration

The wireless versions of the SE7000 provide a simple yet powerful solution which targets such retrofit installations where running new communication wiring is cost prohibitive. The wireless room controllers can dramatically reduce project installation costs by re-using the existing control wiring already in place between older electronic thermostats and the terminal equipment. No new network wires are required since the controllers rely on a fully integrated ZigBee wireless mesh network infrastructure. Connecting wireless SE7000 series devices into an iBMS network is made easy with two integration methods, either via a gateway or a wireless serial adapter.

SmartStruxure™ Lite solution

Designed for small and medium commercial buildings, SmartStruxure™ Lite integrates room controllers using Managers (MPM-GW, MPM-UN, MPM-VA), and provides remote management and supervision of the system through StruxureWare™ Building Expert, a Web iBMS hosted directly by the MPM. For more information, visit <http://documentation.smartstruxurelite.com>



Part Number	Description
MPM-GW, MPM-UN, MPM-VA	Managers (MPM) from the SmartStruxure Lite line of products

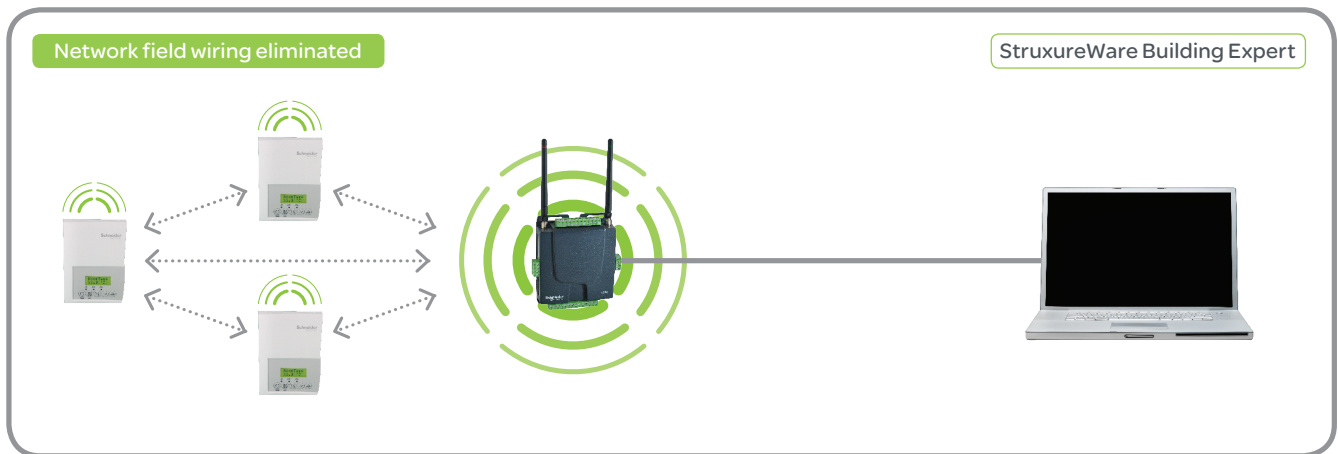

Appendix B

Optional Network Wiring for Communication Models Use

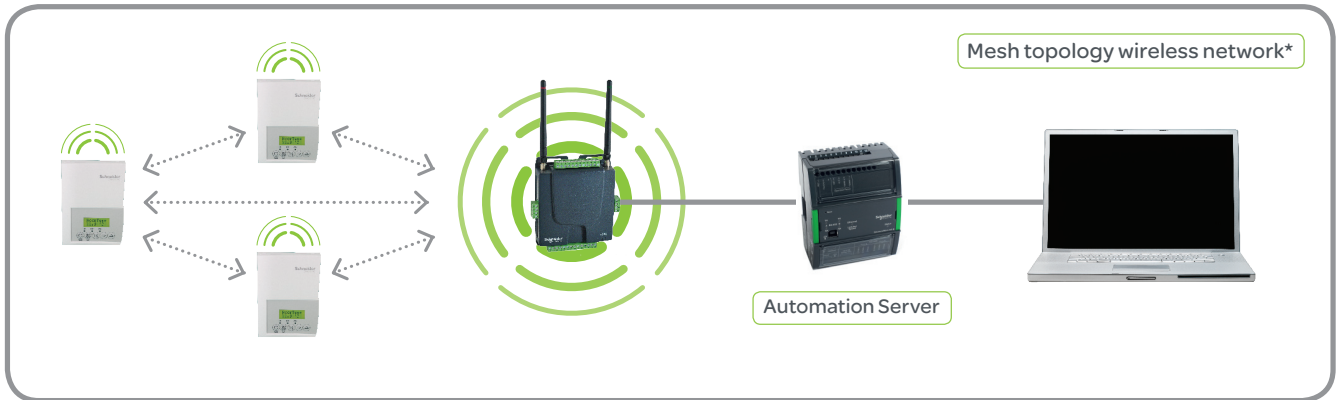

* The MPM models correspond to Room Controllers using ZigBee Pro (P) communications only.

Wireless gateway

The VWG-50-5045 gateway connects up to 50 wireless SE7000 devices to an iBMS network using a BACnet MS/TP or BACnet IP connection.



Part Number	Description
VWG-50-5045	Wireless gateway*
VWG-PS-AC-1045	Universal AC power supply (100 - 240 Vac to 15 VDC)

* The VWG-50-5045 does not come with a power supply. A VWG-PS power supply will be required for each gateway.



The wireless gateway corresponds to Room Controllers using proprietary ZigBee wireless (W) communications only.

Wireless serial adapters

Connecting wireless SE7000 devices to an iBMS network can be simplified by adding a wireless module to existing network controllers. This is a more cost-effective solution.



Part Number	Description
VWG-CPP-1045	Wireless Serial Adapter for Andover Continuum ACX/bCX ¹



Part Number	Description
VWG-EPP-1045	Wireless Serial Adapter for TAC I/A Series ENC-520 ²



Part Number	Description
VWG-APP-1000	Wireless Serial Adapter for TAC I/A Series TRD-J 600/700

¹For Andover Continuum ACX with RS-485, an external RS-232 to RS-485 adapter is required.

²For TAC I/A Series ENC-520 applications, a CBL-xxx is required.

The wireless serial adapters correspond to Room Controllers using proprietary ZigBee wireless (W) communications only.

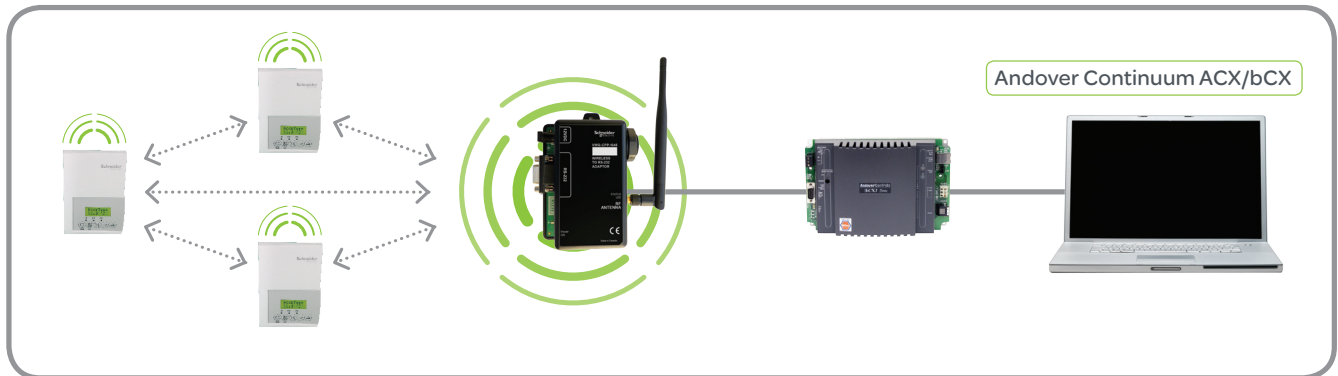

Appendix B

Optional Network Wiring for Communication Models Use

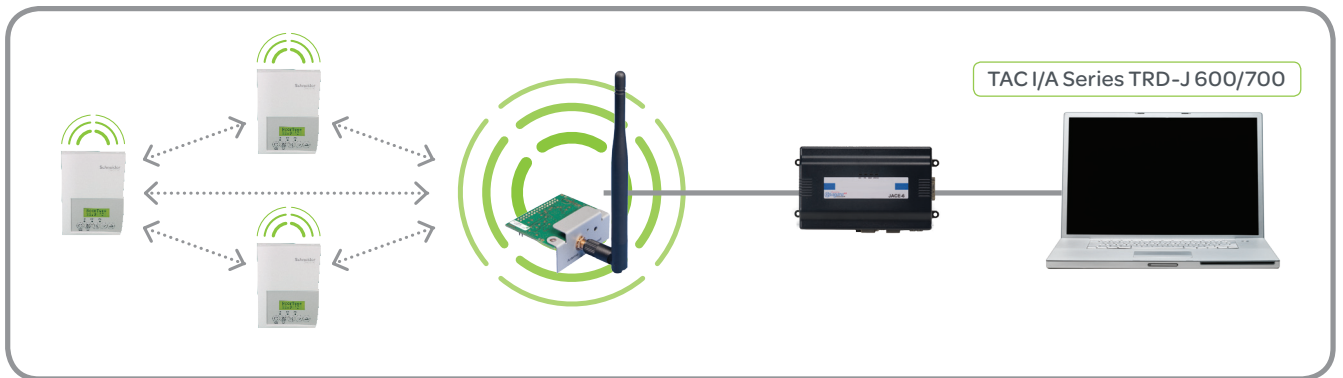

The wireless serial adapters correspond to Room Controllers using proprietary ZigBee wireless (W) communications only.

Wireless accessories



Wireless Repeater

Part Number	Description
VRP5000W1045W	Wireless repeater
VST5000W5045W	Wireless survey tool
VWG-BB-1045	Battery back-up
VWG-RA-1045	Remote antenna
VWG-WA-1045	Whip antenna

Appendix C

Controllers' Occupancy Sequence of Operation Schematic

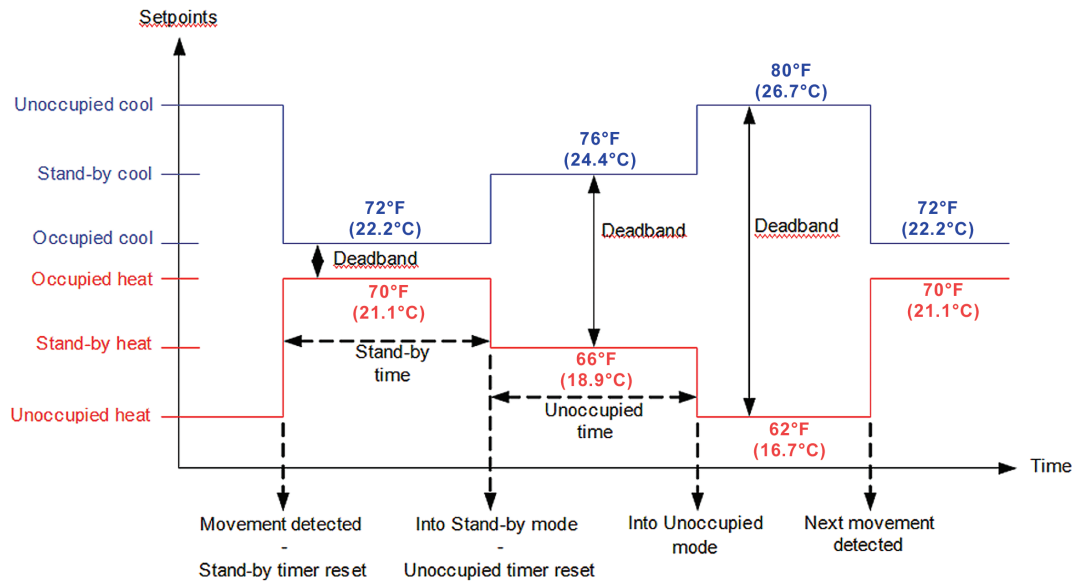



Healthcare

Gain full room control of your environment, whether it's a patient room, waiting room, or anywhere within your facility. The SE7000 Series gives you the flexibility to customise and configure based on your needs.



Retail

Enhance your system operation and efficiency with SE7000 Series room controllers. From a stand-alone device to simplified building management, our room controllers are ideal for your ever-changing location.



Education

Whether it's a large campus with multiple buildings or a single primary school, the SE7000 Series allows for scalability to control a wide variety of environments through occupied and unoccupied periods.



Hotels/Lodging

Guest comfort meets energy efficiency with the SE7000 Series. The intuitive user interface allows guests to control their own environments while our occupancy sensor and simple programming ensure efficiency.



Commercial buildings

The SE7000 Series room controllers allow users to save costs and energy while providing a comfortable environment for maximum productivity. The system can be modified on site to match your specific energy conservation needs.